



User's Guide

RJ-3230B

RJ-3250WB

Table of Contents

Before You Use Your Brother Machine	1
Definitions of Notes	2
Safety Precautions	3
General Precautions	7
Trademarks and Licenses	8
Open Source Licensing Remarks	9
Important Note	10
Set Up Your Printer	11
Parts Description	12
Control Panel Overview	13
LCD Overview	15
LED Patterns and Indications.....	17
Install the Battery	19
Charge the Battery	20
Turn Power On/Off	23
Set the Language	24
Load the Roll	25
Attach the Belt Clip.....	29
Install Software	30
Install Printer Drivers and Software on a Computer	31
Available Applications.....	32
Connect the Printer to a Computer or Mobile Device.....	33
Connect the Printer to a Computer Using a USB Cable.....	34
Connect the Printer to a Computer Using Wi-Fi	35
Connect the Printer to a Computer Using Bluetooth Connection	38
Connect the Printer to a Mobile Device Using NFC (Android)	39
Create and Print Labels Using Your Computer	40
Create Labels Using P-touch Editor (Windows).....	41
Main Window of P-touch Editor Express Mode (Windows)	42
Main Window of P-touch Editor Professional Mode (Windows)	43
Main Window of P-touch Editor Snap Mode (Windows).....	44
Print Labels Using P-touch Editor (Windows)	45
Insert the Date and Time into a Label	46
Create Labels and Print without Installing Software and Drivers	47
Print Using the USB Interface (Mass Storage Mode).....	48
Print Image Data without Using the Printer Driver.....	49
Print Labels Using the Printer Driver (Windows).....	50
Print Labels Using Mobile Devices	51
Available Software	52
AirPrint Overview	53
Transfer Templates Created on a Computer to the Printer Using a Mobile Device	54
Transfer Templates to the Printer (P-touch Transfer Manager) (Windows)	55
Transfer Templates to the Printer Using P-touch Transfer Manager (Windows).....	56
Notes on Using P-touch Transfer Manager (Windows).....	57

Transfer Templates from the Computer to the Printer (Windows)	58
Back up Templates or Other Data Saved in the Printer (Windows).....	66
Delete Printer Data (Windows).....	67
Create Transfer Files and Transfer Package Files (Windows).....	68
Distribute Templates to be Transferred to Users Without Using P-touch Transfer Manager (Windows)	70
Store or Manage Templates (P-touch Library)	74
Edit Templates Using P-touch Library (Windows).....	75
Print Templates Using P-touch Library (Windows).....	76
Search Templates Using P-touch Library (Windows).....	77
Network	79
Important Information for Security	80
Wireless Network Settings	81
Use the Wireless Network	82
Enable/Disable Wi-Fi.....	84
Network Features.....	85
Synchronize Time with the SNTP Server Using Web Based Management	86
Brother Management Tools.....	89
Security	90
Before Using Network Security Features	91
Configure Certificates for Device Security	92
Supported Security Certificate Features	93
Step by Step Guide for Creating and Installing a Certificate	94
Create a Self-signed Certificate	95
Create CSR and Install a Certificate from a Certificate Authority (CA)	96
Import and Export the Certificate and Private Key	100
Import and Export a CA Certificate.....	103
Manage Multiple Certificates	106
Use SSL/TLS	107
Introduction to SSL/TLS	108
Manage Your Network Machine Securely Using SSL/TLS.....	111
Print Documents Securely Using SSL/TLS	116
Use SNMPv3.....	118
Manage Your Network Machine Securely Using SNMPv3	119
Use IEEE 802.1x Authentication for a Wired or a Wireless Network	120
What Is IEEE 802.1x Authentication?	121
Configure IEEE 802.1x Authentication for a Wired or Wireless Network Using Web Based Management (Web Browser).....	122
IEEE 802.1x Authentication Methods.....	124
Update	125
Update P-touch Editor.....	126
Update the Firmware.....	128
Printer Settings	130
Change Printer Settings Using the Printer Setting Tool (Windows)	131
Communication Settings of the Printer Setting Tool (Windows).....	133
Device Settings of the Printer Setting Tool (Windows).....	140
P-touch Template Settings of the Printer Setting Tool (Windows).....	145
The Paper Size Setup Feature of the Printer Setting Tool (Windows)	147





Apply Setting Changes to Multiple Printers (Windows).....	152
Change Printer Settings Using Web Based Management	153
Set or Change a Login Password for Web Based Management.....	154
Confirm Printer Settings	155
Change Printer Settings Using the Printer	156
Settings Tables	157
Routine Maintenance	160
Maintenance.....	161
Troubleshooting	164
If You Are Having Difficulty with Your Machine	165
Error and Maintenance Messages	166
Printing Problems.....	168
Network Problems.....	172
Version Information.....	175
Reset the Printer	176
Battery Charger (Optional) Problems.....	177
Active Docking Station (Optional) Problems	178
Linerless Platen Upgrade (Optional) Problems.....	179
Appendix.....	180
Specifications	181
Software Development Kit.....	184
Optional Accessories	185
Battery Charger (Optional: PA-BC-003)	186
Label Peeler (Optional: PA-LP-007)	192
Linerless Platen Upgrade (Optional: PA-LPR-004)	197
Single Active Docking Station (Optional: PA-CR-005).....	200
4-bay Active Docking Station (Optional:PA-4CR-003).....	207
Product Dimensions	215
Brother Help and Customer Support.....	223
Compatible Operating Systems	225
International ENERGY STAR® Qualification Statement (USA and Canada Only).....	226

Before You Use Your Brother Machine

- [Definitions of Notes](#)
- [Safety Precautions](#)
- [General Precautions](#)
- [Trademarks and Licenses](#)
- [Open Source Licensing Remarks](#)
- [Important Note](#)

Definitions of Notes

We use the following symbols and conventions throughout this User's Guide:

 DANGER	DANGER indicates an imminently hazardous situation which, if not avoided, will result in death or serious injuries.
 WARNING	WARNING indicates a potentially hazardous situation which, if not avoided, could result in death or serious injuries.
 CAUTION	CAUTION indicates a potentially hazardous situation which, if not avoided, may result in minor or moderate injuries.
IMPORTANT	IMPORTANT indicates a potentially hazardous situation which, if not avoided, may result in damage to property or loss of product functionality.
NOTE	NOTE specifies the operating environment, conditions for installation, or special conditions of use.
	The tips icon indicates helpful hints and supplementary information.
Bold	Bold style identifies buttons on the machine's control panel or computer screen.
<i>Italics</i>	Italicized style emphasizes an important point or refers you to a related topic.
Courier New	Courier New font identifies messages shown on the machine's LCD.

Related Information

- [Before You Use Your Brother Machine](#)

Safety Precautions

Follow these guidelines to avoid the risk of smoke or heat generation, explosion, fire, or injury.

DANGER

Rechargeable Li-ion Battery

Carefully observe the following precautions for the rechargeable Li-ion battery (hereafter referred to as “rechargeable battery”). If these precautions are not followed, overheating, leaking, or cracks in the battery may result in an electrical short, explosion, smoke, fire, electrical shock, injury to yourself or others, or damage to the product or other property.

- Use only for its intended purpose.
- DO NOT attempt to charge the battery using an unsupported charger.
- DO NOT charge, use, or leave the battery in high-temperature (above 60°C /140°F) locations.
- DO NOT allow the rechargeable battery to come into contact with or to be immersed in water.
- Keep away from heat and fire.
- DO NOT connect the + and - terminals with metal objects such as wire. DO NOT carry or store the battery with metal objects.
- DO NOT throw, hit or damage the battery in any way.
- DO NOT solder any connections to the battery.
- DO NOT disassemble, modify, or attempt to repair the rechargeable battery.
- Dispose of batteries at an appropriate collection point. Be sure to observe all applicable local regulations.
- When charging the rechargeable battery, use the battery charger designed specifically for the rechargeable battery.
- DO NOT use the rechargeable battery in corrosive environments, such as areas where salty air, salt water, acids, alkalis, corrosive gases, chemicals, or any corrosive liquid is present.
- DO NOT use the rechargeable battery if it is damaged or leaking.
- DO NOT use the rechargeable battery with the polarity (+) (-) reversed. Check the orientation of the rechargeable battery before inserting it, and do not try to force the rechargeable battery into your printer. Charging the rechargeable battery with the polarity reversed could cause an abnormal chemical reaction within the rechargeable battery or abnormal current flow during discharge.
- DO NOT directly connect the rechargeable battery to a household electrical supply.
- Liquid (electrolyte) leaking from your printer or rechargeable battery may indicate that the rechargeable battery is damaged. If the rechargeable battery leaks, immediately stop using your printer and isolate your printer by placing it in a bag.

DO NOT touch the electrolyte. If electrolyte gets in the eyes, do not rub them and obtain medical attention. Immediately wash out the eyes with water continuously for at least 15 minutes. If left alone, the electrolyte could cause eye damage. If electrolyte contacts your skin or clothing, immediately rinse them with water.

- DO NOT put the rechargeable battery, or a printer with the rechargeable battery installed, into a microwave oven or a high-pressure container.
- DO NOT dispose of the rechargeable battery in fire or intentionally overheat. This could cause the internal insulation to melt, gas to be emitted, or safety mechanisms to fail. Additionally, the electrolyte solution could catch fire.
- DO NOT leave a drained rechargeable battery in your printer for a long period of time. This could shorten the life of the rechargeable battery or lead to an electrical short.
- If your printer can only be used for a short period of time, even though the rechargeable battery is fully charged, the rechargeable battery may have reached the end of its service life. Replace the rechargeable battery with a new one. When removing and replacing the rechargeable battery, cover the terminals of the old rechargeable battery with tape to avoid creating a short in the battery.

WARNING

Printer

- DO NOT use the printer where its use is prohibited, such as on an airplane. This could affect the airplane's equipment, resulting in an accident.
- DO NOT use the printer in special environments, such as near medical equipment. Electromagnetic waves may cause the medical equipment to malfunction.
- DO NOT place the product near chemicals or in a place where chemical spillage could occur. DO NOT allow organic solvents, such as benzene, thinner, polish remover, or deodorizers, to come into contact with the plastic cover or cables. These may cause the plastic cover to warp or dissolve, resulting in an electrical shock or fire. They may also cause the product to malfunction or become discolored.

Printer, AC Adapter (Optional), or Car Adapter (Optional)

- When foreign objects are inserted into the printer or its connectors and ports, stop using the printer and turn off the power. Then disconnect any cables connected to the printer or remove the battery.
- DO NOT insert foreign objects into the AC Power Cord's connector, otherwise burns or electrical shock may occur.
- DO NOT operate or store your printer in the following locations, otherwise a fire, electrical shock, or damage may occur:
 - Near water, such as in a bathroom or near a water heater, or in an environment where the humidity is less than 10% or greater than 90% for operation.
 - In a location where it is exposed to rain or moisture
 - In an extremely dusty location
 - In an environment where the temperature is less than -4°F (-20°C) or greater than 131°F (55°C) for operation, such as near open flames, heaters, or in direct sunlight
 - In a closed car in direct sunlight
 - In a location where condensation may form
- DO NOT touch the AC Adapter and the product during a thunderstorm.
- DO NOT touch any connection ports with wet hands, otherwise an electrical shock, equipment damage, smoke generation or fire may occur.
- DO NOT disassemble or alter the product.
- DO NOT pour chemicals or use combustible sprays on the product.

Examples of combustible sprays:

- Dust-removing cleaners
- Pesticides
- Disinfectants and deodorizers that contain alcohol
- Organic solvents or liquids such as alcohol
- Use and store the printer, other components, and packing bags out of the reach of children.
- Remove the battery or disconnect the cord when shipping.
- If the printer is not in use for long periods, remove the battery and disconnect the cord before storing.
- DO NOT place heavy objects on the printer or the USB cable.
- DO NOT forcibly bend or pull the USB cable.

Rechargeable Li-ion Battery

- Keep away from infants. If ingested, contact emergency services immediately.
- Stop using the battery if there are noticeable abnormalities such as smell, heat, deformities, or discoloration.

AC Adapter (Optional), Car Adapter (Optional)

- Use only with the specified product.
- Insert the plug firmly into the outlet.
- Use the AC Adapter with an AC 100 V - 240 V 50/60 Hz household outlet and Car Adapter with DC 12 V.

- DO NOT allow metal objects to come into contact with connectors and ports.
- DO NOT pull on the cord when disconnecting the AC Adapter cord. Hold the plug and pull it out of the electrical outlet.
- DO NOT damage, twist, severely bend, pull on, place objects on, or bind the AC Adapter and Car Adapter.
- DO NOT pinch or pierce the AC Adapter and Car Adapter cords.
- DO NOT overload electrical outlets.

⚠ CAUTION

Printer

- DO NOT touch the blade or Print Head. Doing so could cause injury.
- DO NOT hold the printer by the Roll Compartment Cover or the Roll Guide. There is a risk that the cover could detach or the printer could fall.
- When connecting cables and accessories, follow the applicable instructions.
- DO NOT touch the Print Head and metal parts surrounding the Print Head.

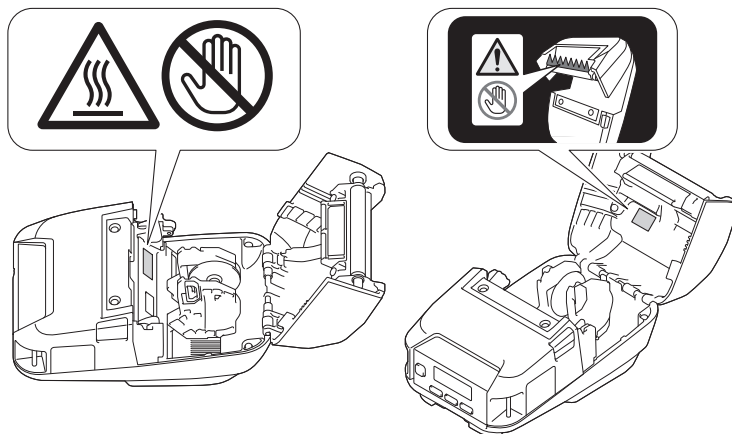

- If the printer is used for a long period of time, the highlighted printer parts may get hot enough to cause a low-temperature burn.

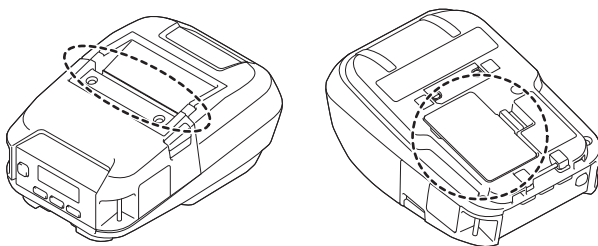

Rechargeable Li-ion Battery

- If liquid from the battery gets onto skin or clothes, immediately rinse with water.

AC Adapter (Optional), Car Adapter (Optional)

- Make sure you can always access the adapter cord so that you can disconnect it immediately in the event of an emergency.

Belt Clip

- Make sure that the Belt Clip is attached securely to the printer and the wearer's belt.

IMPORTANT

- DO NOT remove the labels affixed to the printer. These labels provide operational information and indicate the printer's model number.
- DO NOT push the power button or LED indicator with an object that has a sharp point, such as a pen. This could damage the button or LED.

-
- DO NOT transport the printer while cables are connected to the printer's DC connector or USB port. The connector and ports could be damaged.
 - DO NOT store the printer in an area exposed to high temperatures, high humidity, direct sunlight, or dust. These could cause discoloration or a malfunction.
-



Related Information

- [Before You Use Your Brother Machine](#)
-

General Precautions

Printer

- Depending on the area, material, and environmental conditions, the label may unpeel or become permanently affixed, and the color of the label may change or be transferred to other objects. Before affixing the label, check the environmental conditions and the material. Test the label by affixing a small piece of it to an inconspicuous area of the intended surface.
- If the Bluetooth and wireless LAN functions are both turned on, the communication speed may decrease due to radio wave interference. If this occurs, turn off the function you are not using (the Bluetooth or wireless LAN function).
- DO NOT cover, or insert foreign objects into the Paper Exit Slot, DC Connector, or USB port.
- DO NOT use paint thinner, benzene, alcohol or any other organic solvents to clean the printer. Doing so may cause damage to the surface finish. Use isopropyl alcohol or ethanol only when cleaning the print head or roller. Use a soft, dry cloth to clean the printer.
- When not in use for a period of time, remove the Label Roll from the printer.
- Always keep the Roll Compartment Cover closed when printing.
- This printer uses thermal paper. If the printed paper is marked with ink, for example written on or stamped, the ink may cause the printed text to fade or become discolored. In addition the applied ink may take some time to dry.

Printed text may fade or become discolored if the label comes into contact with any of the following: vinyl chloride products, leather goods such as wallets and purses, organic compounds such as alcohol, ketones, or esters, adhesive tape, erasers, rubber mats, magic marker ink, permanent marker ink, correction fluid, carbon, glue, diazo sensitized paper, hand lotion, hair care products, cosmetics, water, or sweat.

- DO NOT touch the printer with wet hands.
- DO NOT use folded, wet or damp paper, otherwise a paper misfeed or malfunction may occur.
- DO NOT touch paper or labels with wet hands, otherwise a malfunction may occur.

Printer, AC Adapter (Optional), Car Adapter (Optional), or Accessories

- Observe all applicable regulations when disposing of these products.



Related Information

- [Before You Use Your Brother Machine](#)

Trademarks and Licenses

- Apple, App Store, Mac, Safari, AirPrint, the AirPrint logo, iPad, iPhone, iPod touch, macOS and iPadOS are trademarks of Apple Inc., registered in the United States and other countries.
- Android and Google Chrome are trademarks of Google LLC.
- The Bluetooth® word mark and logos are registered trademark owned by Bluetooth SIG, Inc. and any use of such marks by Brother Industries, Ltd. is under license. Other trademarks and trade names are those of their respective owners.
- QR Code is a registered trademark of DENSO WAVE INCORPORATED.
- Epson ESC/P is a registered trademark of Seiko Epson Corporation.
- Wi-Fi® is a registered trademark of Wi-Fi Alliance®.
- Wi-Fi Protected Setup™ is a trademark of Wi-Fi Alliance®.
- Mozilla and Firefox are registered trademarks of the Mozilla Foundation.
- QR Code Generating Program Copyright © 2008 DENSO WAVE INCORPORATED.
- BarStar Pro Encode Library (PDF417, Micro PDF417, DataMatrix, MaxiCode, AztecCode, GS1 Composite, GS1 Databar, Code93, MSI/Plessey, POSTNET, Intelligent Mail Barcode)
Copyright © 2007 AINIX Corporation. All rights reserved.
- Blue SDK
Copyright © 1995-2021 OpenSynergy GmbH.
All rights reserved. All unpublished rights reserved.
- Portions of this software are copyright © 2014 The FreeType Project (www.freetype.org). All rights reserved.

Any trade names and product names of companies appearing on Brother products, related documents and any other materials are all trademarks or registered trademarks of those respective companies.



Related Information

- [Before You Use Your Brother Machine](#)

Open Source Licensing Remarks

This product includes open source software.

To see the Open Source Licensing Remarks, go to your model's **Manuals** page on the Brother support website at support.brother.com.



Related Information

- [Before You Use Your Brother Machine](#)
-

Important Note

- The contents of this document and the specifications of this product are subject to change without notice.
- Brother reserves the right to make changes without notice in the specifications and materials contained herein and shall not be responsible for any damages (including consequential) caused by reliance on the materials presented, including but not limited to typographical and other errors relating to the publications.
- Screen images in this document may differ depending on your computer's operating system, your product model, and software version.
- Before using the printer, make sure you read all the documents included with the printer for information about safety and operation.
- The printer shown in the illustrations may be different from your printer.
- The available supplies may vary depending on your country or region.
- We recommend using the latest version of P-touch Editor.
- To keep your machine performance up to date, check support.brother.com for the latest firmware upgrade. Otherwise, some of your machine's functions may not be available.
- When replacing or disposing of your machine, Brother strongly recommends resetting it to its factory settings to remove all personal information.



Related Information

- [Before You Use Your Brother Machine](#)
-

Set Up Your Printer

- [Parts Description](#)
- [Control Panel Overview](#)
- [LCD Overview](#)
- [LED Patterns and Indications](#)
- [Install the Battery](#)
- [Charge the Battery](#)
- [Turn Power On/Off](#)
- [Set the Language](#)
- [Load the Roll](#)
- [Attach the Belt Clip](#)

Parts Description

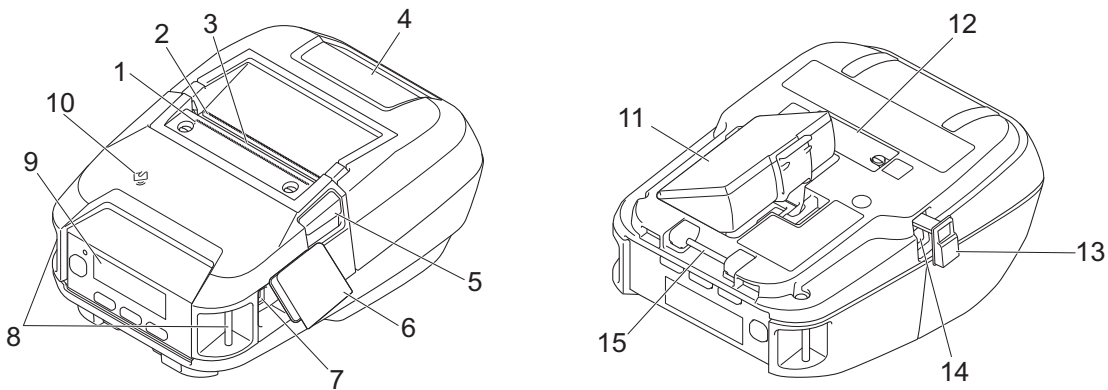

1. Upper Tear Bar
2. Lower Tear Bar
3. Paper Exit Slot
4. Roll Compartment Cover
5. Roll Cover Release Lever
6. Interface Cover
7. USB TypeC Port
8. Shoulder Strap Slots
9. Control Panel
10. Near-Field Communication (NFC) Sensor
11. Battery Compartment
12. Docking Station Terminal Cover
13. DC Connector Cover
14. DC Connector
15. Belt Clip Hook



The serial number and MAC address labels are located on the base of the printer.

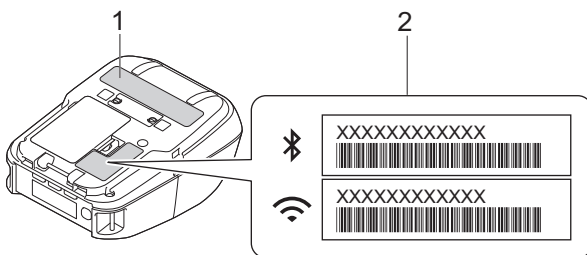

1. Serial number
2. MAC address

✓ Related Information

- [Set Up Your Printer](#)



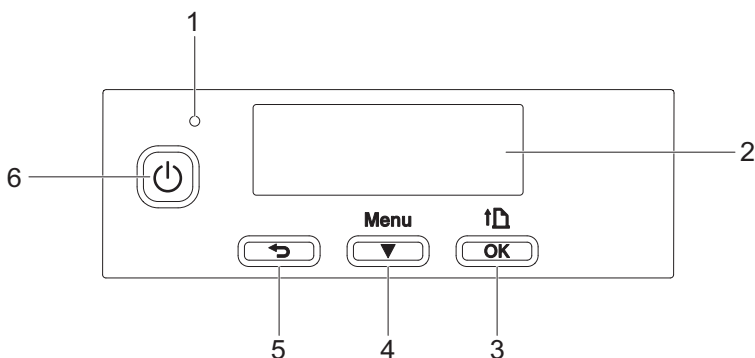

Related Topics:

- [Control Panel Overview](#)

Control Panel Overview





1. LED Indicator
2. LCD
3.  (Feed) / **OK** Button

Function	Operation
Feed the paper	When the paper type is set to Die-cut Label or Media With Marks : Press  to automatically feed the paper to the print position. When the paper type is set to Continuous Length Tape : Press  to feed the paper.
Print the printer information	Make sure that a roll is set, and then press and hold  to print the printer information.
Activate the selected menu option	Press  to activate the selected menu option.

4. **Menu / ▼** (Select) Button



Function	Operation
Enter the menu selection mode	While the printer is turned on, press the Menu / ▼ (Select) button.
Select the menu option	When the menu is displayed, press the Menu / ▼ (Select) button to select the next option.
Execute a file stored in the mass storage area	If you press this button while the printer is running in mass storage mode, you can execute a command file stored in the mass storage area. For more information, see <i>Related Topics</i> .

5.  (Back) Button

Function	Operation
Clear the selected menu item and return to the previous screen.	Press the  (Back) button to return to the previous setting category.
Cancel the current print job.	Press the  (Back) button to cancel the current print job.

6.  (Power) Button

Function	Operation
Turn on the printer	While the printer is turned off, press the  (Power) button.

Function	Operation
Turn off the printer	While the printer is turned on, press the  (Power) button until the message <i>System Off</i> appears on the LCD. (If the Auto Power Off feature is enabled in the Device Settings, the printer will turn itself off automatically after the selected period of inactivity.)
Start the printer in mass storage mode	If you press and hold the  (Power) button while also pressing the Menu / ▼ (Select) button, the printer starts in mass storage mode. For more information, see <i>Related Topics</i> .



Related Information

- [Set Up Your Printer](#)

Related Topics:

- [LCD Overview](#)
 - [LED Patterns and Indications](#)
 - [Print Using the USB Interface \(Mass Storage Mode\)](#)
-

LCD Overview

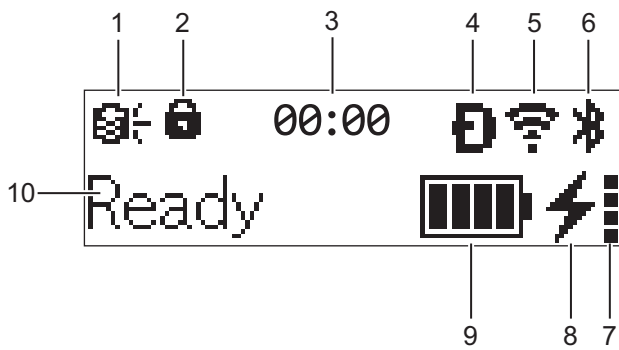

1. Update

Indicates the FTP connectivity and update status.

	There is new data.
	Data update is unsuccessful.
	Cannot connect to the server.

2. Menu Key Lock

Displays when the **Menu Key Function** in Printer Setting Tool is set to **Disable**.

3. Clock

Displays when [Clock] is set to [On].

4. Wireless Direct (RJ-3250WB)

Indicates if Wireless Direct is available.

5. WLAN (RJ-3250WB)

	Your printer is connected to the wireless network.
	Your printer is searching for a wireless network.

6. Bluetooth

Indicates if Bluetooth is on. When the icon is flashing, the printer is automatically re-pairing. For more information, see *Related Topics*.



7. Battery health level

The Battery health level icon does not appear when charging is not possible.

Message	Icon	Condition
BatteryHealth Excellent		No problems. The battery may be used.
BatteryHealth Good		Still healthy. The battery can be used.
Battery Poor Replace soon		Battery health is deteriorating.
Batt.VeryPoor Replace battery		The battery is badly deteriorated.





8. Charge status

Displays the charge status of the battery.

	Charging
	Not Charging (The battery cannot be charged if its temperature is above 104°F (40°C) or below 32°F (0°C).)
No icon	Charging is finished or paused

9. **Battery level**

Indicates the remaining battery level.

	Full
	High
	Half
	Low

10. **Printer status**

Displays the printer status.



Related Information







- [Set Up Your Printer](#)









Related Topics:



- [Communication Settings of the Printer Setting Tool \(Windows\)](#)

LED Patterns and Indications

The indicator lights and flashes to indicate the printer's status. The symbols used in this section explain the meaning of the different indicator colors and patterns:

 or  or 	Indicator is lit in the color shown.
 or  or 	Indicator is flashing in the color shown.
	Indicator is off.

LED Indicator	Status
	Power off
	Charging complete (when power is turned off)
	Not charging (when power is turned off)
	Battery level: Half or more
	Charging complete (when power is turned on)
	Power on
	Not charging (when power is turned on)
	Charging
	Boot mode
	 If the indicator is lit in red (Boot mode), contact Brother Customer Service.
 (Flashing rapidly every two seconds)	Battery level: low
 (Flashing once every three seconds)	Sleep mode and charging
	Sleep mode
	Roll end error
	Feed error
	Cover open error
	Communication error
	WPS connection error
	BLF file error
	No template error
	Memory full error
	ESC/P Memory full error
	JPEG file error
	Battery deterioration error
	Mass storage error
	Battery level: empty
System error	

LED Indicator	Status
	Database search error
	Battery error (if the battery is not fully charged after the specified amount of time)
	Set clock error
	Remaining battery error
	The peeler function cannot be used due to strong ambient light.



Related Information

- [Set Up Your Printer](#)

Install the Battery

Make sure you charge the Rechargeable Li-ion battery (PA-BT-006) either in the printer or on the battery charger before initial use.

1. Unlock the battery, and then remove it.

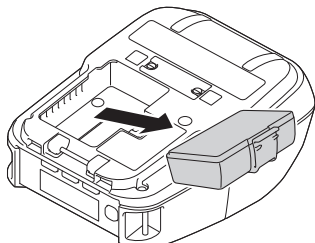

2. Remove the insulating sheet.

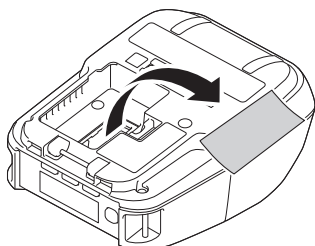

3. Insert the battery until it locks into place.

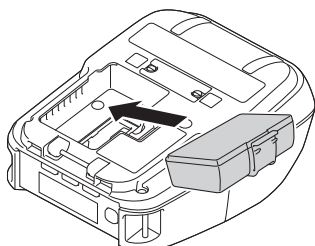

Related Information

- [Set Up Your Printer](#)

Charge the Battery

- >> [Tips on Using the Battery](#)
- >> [Charge the Battery Using a USB Cable](#)
- >> [Charge the Battery Using an AC Adapter \(Optional\)](#)
- >> [Charge the Battery Using a Car Adapter \(Optional\)](#)
- >> [Charge the Battery Using the Battery Charger \(Optional\) or the Active Docking Station \(Optional\)](#)
- >> [Stop Charging the Battery](#)

Tips on Using the Battery

Fully charge the rechargeable battery before using the printer.



- High-density (dark) printing discharges the battery faster than low-density printing. Adjust the print density setting in the Device Settings. For more information, see *Related Topics*.
- The battery charging must take place in an environment with a temperature between 32°F and 104°F (0°C and 40°C), otherwise the battery will not be charged. If the charging stops because the environment temperature is too low or too high, place the printer in an environment with a temperature between 32°F and 104°F (0°C and 40°C) and try charging again.
- The recommended charging temperature range for the battery is from 41°F to 95°F (5°C to 35°C).
- If you use the printer when both the battery is installed and the AC Adapter or Car Adapter is connected, charging may stop even if the battery is not fully charged.

Battery Characteristics

To ensure the highest performance and longest life from the battery:

- Do not use or store the battery in a location exposed to extreme high or low temperatures as it may deteriorate more quickly.
- Remove the battery when storing the printer for long periods of time.
- Store batteries with less than a 50% charge in a cool dry place and out of direct sunlight.
- Recharge the battery every six months if it is stored for long periods of time.
- It is normal and safe for the printer to become warm while charging. Disconnect the charger and stop using the printer if it becomes hot to the touch.
- When the printer is turned on, the battery health status appears on the LCD.

For the battery health level indication, see *Related Topics*.

Charge the Battery Using a USB Cable



- The USB TypeC cable is not included.
 - Compatible USB cable: USB TypeC to USB TypeC (5 V, 1.5 A or more)
 - Compatible USB charger: USB TypeC (5 V, 1.5 A or more)

1. Make sure that the battery is installed in the printer.
2. Open the USB Port Cover.
3. Connect the USB cable to the USB port on the printer, and then either to your computer or to a compatible USB charger.

Charge the Battery Using an AC Adapter (Optional)

The AC Adapter and AC power cord are optional accessories. When purchasing the printer, purchase the correct AC Adapter and AC power cord for the region where the printer will be used.

1. Make sure that the battery is installed in the printer.
2. Open the DC Connector Cover and connect the AC Adapter (PA-AD-600A) to the printer.
3. Connect the AC power cord to the AC Adapter.
4. Connect the AC power cord to a nearby AC power outlet (100 V AC - 240 V AC, 50/60 Hz).

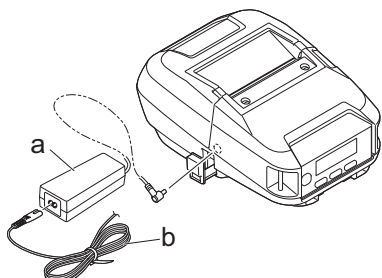

- a. AC Adapter
- b. AC power cord

Charge the Battery Using a Car Adapter (Optional)

Connect the printer to your vehicle's 12 V DC power outlet (cigarette lighter or similar) to charge the rechargeable battery.



The Car Adapter is an optional accessory.

1. Make sure that the battery is installed in the printer.
2. Connect the Car Adapter (PA-CD-600CG/PA-CD-600CGS/PA-CD-600WR) to the vehicle's 12 V DC power outlet.
3. Open the DC Connector Cover and connect the Car Adapter to the printer.

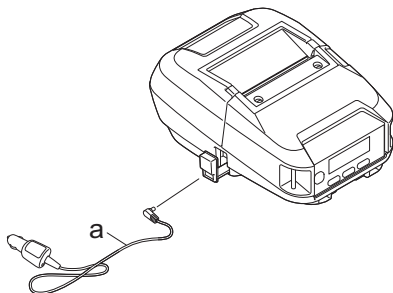

- a. Car Adapter

Charge the Battery Using the Battery Charger (Optional) or the Active Docking Station (Optional)

The battery can be charged using the Battery Charger (Optional) or the Active Docking Station (Optional). For more information, see *Related Topics*.

Stop Charging the Battery

To stop the battery charging, disconnect the printer from the computer or power source.

✓ Related Information



- [Set Up Your Printer](#)

Related Topics:

- [Device Settings of the Printer Setting Tool \(Windows\)](#)

-
- LCD Overview
 - Single Active Docking Station (Optional: PA-CR-005)
 - 4-bay Active Docking Station (Optional:PA-4CR-003)
 - Battery Charger (Optional: PA-BC-003)
-

Turn Power On/Off

- To turn on the printer, press .
The Power LED lights in green.
- To turn off the printer, press  until the message [System Off] appears on the LCD.

NOTE





- When the printer is connected to the AC Adapter, it turns on automatically by default.
- Do not remove the battery until the LCD turns off when the AC Adapter is not connected to the printer and the AC power outlet.



Related Information

- [Set Up Your Printer](#)
-

Set the Language

1. Press the **Menu / ▼** (Select) button to select the [Settings] menu, and then press the  (Feed) / **OK** button.
2. Select  [Language], and then press the  (Feed) / **OK** button.
3. Select a language, and then press the  (Feed) / **OK** button.



Related Information

- [Set Up Your Printer](#)
-

Load the Roll

- >> Load the Roll
- >> Change the Media Roll Holders to Use Custom-Size Media
- >> Use the Roll Holder Stop
- >> Tear-Off Media

Load the Roll

1. Push the Roll Cover Release Lever to open the Roll Compartment Cover.

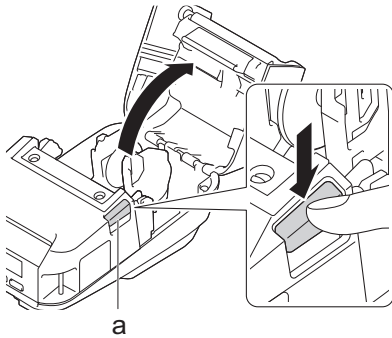

a. Roll Cover Release Lever

2. Slide both Roll Guides outward.

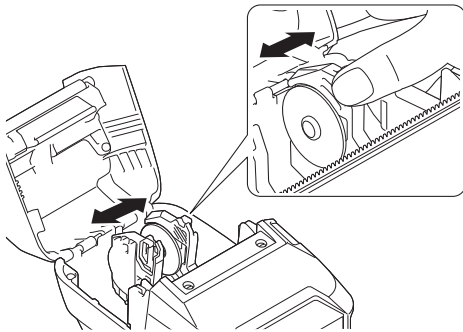

3. Make sure that the roll is correctly aligned, and then insert it into the Roll Compartment.

NOTE

If the core of the roll is protruding, flatten the edges before setting, as illustrated.

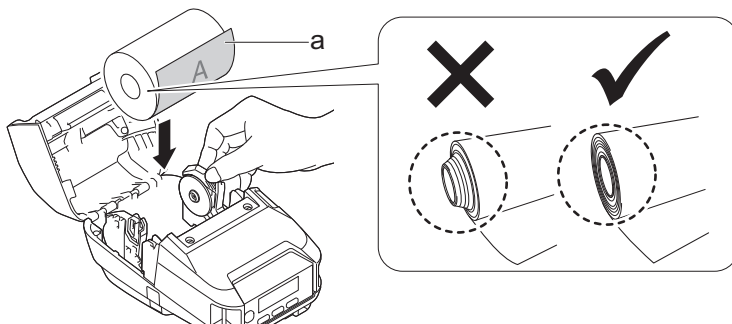

a. Print surface (faces outward on the roll)

4. Close the Roll Compartment Cover until it locks into place.

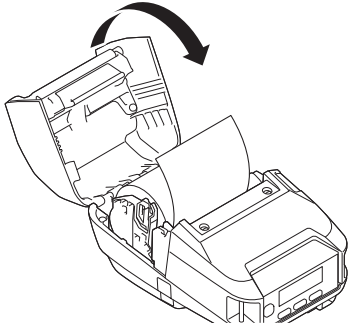

5. If the LCD shows [Select Media] or [Auto Detect], select the option you want. To configure these settings later, go to the [Media].

NOTE

For best performance, use genuine Brother media.



- When using die-cut labels, set the paper type to **Die-cut Label**, and press the  (Feed) / **OK** button after inserting the roll. The printer will feed the label to the top of form position.
- To remove the roll, reverse the loading procedure.
- Make sure the inserted roll turns freely between the Roll Guides.

Change the Media Roll Holders to Use Custom-Size Media

To use custom-size media, attach the Media Roll Holders that match your media's core size to the Roll Guides.

NOTE

- Not all types of Media Roll Holders may be supplied with your printer. To purchase additional Media Roll Holders, contact your local Brother dealer.
- To check which media core sizes each Media Roll Holder supports, check the information on the center of the Media Roll Holder.
- If using multi-size Media Roll Holders, make sure the same-size sides face each other when attached to the Roll Guides.

1. Push the Roll Cover Release Lever to open the Roll Compartment Cover.
2. Hold the left Roll Guide so that it does not rotate, and then remove the currently installed Media Roll Holder using a flathead screwdriver.

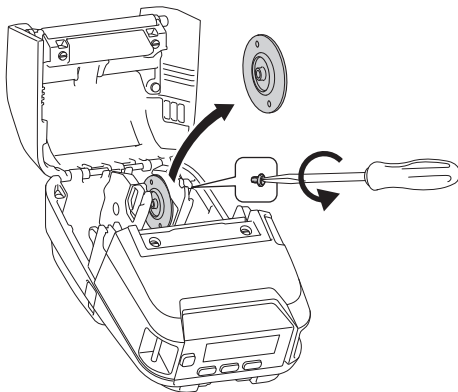

3. Hold the right Roll Guide so that it does not rotate, and then remove the currently installed Media Roll Holder using a flathead screwdriver.
4. Attach the Media Roll Holders that match your media's core size to the Roll Guides using a flathead screwdriver. Make sure you use the same size Media Roll Holders.

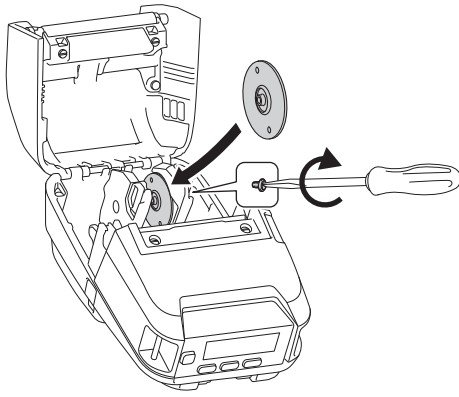

5. Insert the roll. For more information, , see *Related Topics*..
6. Close the Roll Compartment Cover and press until it locks into place.
7. If the LCD automatically shows [Select Media] or [Auto Detect], select the option you want. To configure these settings later, go to the [Media] menu

Use the Roll Holder Stop

The Roll Holder Stop prevents the Roll Guides from closing. It is ideal to reduce the distance needed to extend the Roll Guides to load the roll.

1. Remove the backing paper from the two locations on the Roll Holder Stop, as shown in the illustration.

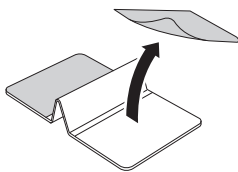

2. Extend the Roll Guides outward and attach the Roll Holder Stop to the innermost part of the groove.

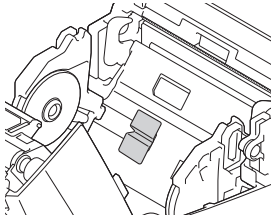

- The Roll Holder Stop is compatible with the 3 inch roll.
- Attach the Roll Holder Stop with the Roll Guides extended outward.
- The Roll Holder Stop can be attached to either side of the groove.
- Attach the Roll Holder Stop to prevent surplus air from accumulating between the adhesive layer and the printer.
- Clean the pasted part of the printer before attaching.

Tear-Off Media

Receipt paper, labels, and tags can be torn off by swiftly pulling up or down on the media according to the set cutting position. Linerless media can only be torn upward.

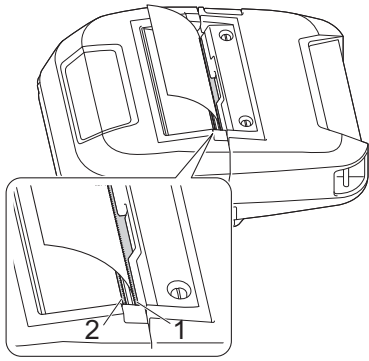

1. Upper Tear Bar
2. Lower Tear Bar

CAUTION

Do not touch the Tear Bar blade.



- The default [Tear Bar] setting is set to [Upward]. (When **Linerless** is set to **On** in the **Advanced** tab of the Printer Setting Tool, the [Tear Bar] setting is not available.)
- To adjust the cutting position, open the Printer Setting Tool, go to **Print Position / Sensors** in the **Device Settings**, and then enter the setting you want in the **Tear Adjust** field. For more information, see *Related Topics*.



Related Information

- [Set Up Your Printer](#)

Related Topics:

- [Device Settings of the Printer Setting Tool \(Windows\)](#)

Attach the Belt Clip

1. Attach the Belt Clip to the Belt Clip Hook on the printer, as shown:

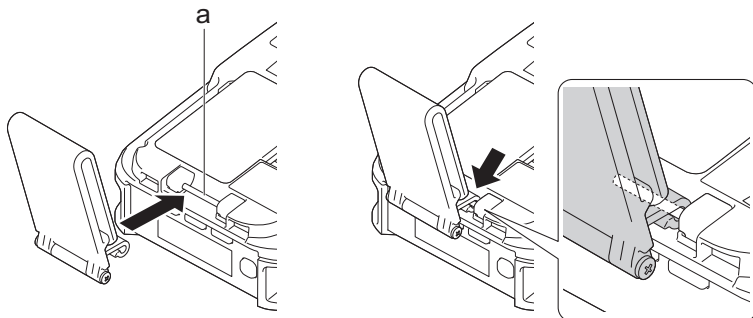

a. Belt Clip Hook

2. Attach the Belt Clip to your belt, as illustrated.

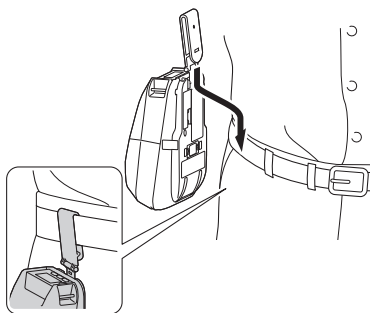

- Make sure you attach the Belt Clip securely to the printer.
- To detach the Belt Clip, reverse the installation procedure.
- We recommend using a belt that is less than 0.2" (5 mm) thick and less than 1 7/8" (47.63 mm) wide.



Related Information

- [Set Up Your Printer](#)

Install Software

- [Install Printer Drivers and Software on a Computer](#)
- [Connect the Printer to a Computer or Mobile Device](#)

Install Printer Drivers and Software on a Computer

To print from your computer, install the printer driver and P-touch Editor on your computer.

1. In the address bar, type install.brother and download the Software/Documentation installer.

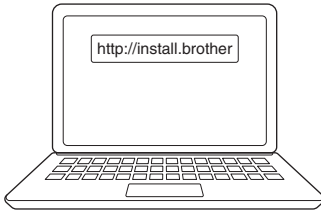

2. Double-click the downloaded installer, and follow the on-screen instructions.

NOTE

- To use your printer's advanced features, select the additional software you want during installation.



(RJ-3250WB)

To connect the printer to a computer using a wireless connection, we recommend the following:

- Make a note of the SSID (Network Name) and Password (Network Key) of the wireless network in advance. If you cannot find this information, contact your network administrator or wireless router/access point manufacturer.
- To connect the printer to a computer using Wireless Direct, select the USB connection during the installation. At the end of the installation, click the link for Wireless Direct.



To use the printer with a different connection method than the one selected during installation, use the installer again to reinstall the software and printer drivers, and select the new connection method.



Related Information

- [Install Software](#)
 - [Available Applications](#)

Available Applications

NOTE

These applications are available only for Windows.

Application	Features
P-touch Editor	Allows you to design and print custom labels using built-in drawing tools to create various font and text styles, import images, and insert barcodes.
P-touch Transfer Manager	Allows you to transfer templates and other data to the printer and save backups of your data on the computer. This application is installed with P-touch Editor.
P-touch Library	Manages and prints P-touch Editor templates. You can use P-touch Library to print templates. This application is installed with P-touch Editor.
P-touch Transfer Express	Allows you to transfer firmware and other parameter packages to the printer. To download the installer, go to your model's Downloads page on the Brother support website at support.brother.com
P-touch Update Software	Confirm and update software and firmware to the latest version.
Printer Setting Tool	Specifies the printer's settings from a computer. <ul style="list-style-type: none"> • Communication Settings • Device Settings • P-touch Template Settings • Paper Size Setup
BRAdmin Light	Finds the printer on your network and allows you to configure basic settings from your computer.
BRAdmin Professional	Finds the printer on your network and allows you to configure basic settings and updates from your computer.
Font Manager	Allows you to transfer fonts to the printer and delete fonts from the printer. Transferred fonts can be accessed and printed using various print commands. To download the installer, go to your model's Downloads page on the Brother support website at support.brother.com <hr/>  <ul style="list-style-type: none"> • Font Permissions When using fonts, you must abide by all the terms and conditions set forth by each rightful font owner. Before downloading fonts, you must confirm that you have legitimate licences to use the fonts and comply with their terms and conditions; otherwise you may not download fonts. <hr/>
Web Based Management	Allows you to use a standard web browser to manage a printer on your network using HTTPS.



Related Information

- [Install Printer Drivers and Software on a Computer](#)

Related Topics:

- [Available Software](#)

Connect the Printer to a Computer or Mobile Device

- [Connect the Printer to a Computer Using a USB Cable](#)
- [Connect the Printer to a Computer Using Wi-Fi](#)
- [Connect the Printer to a Computer Using Bluetooth Connection](#)
- [Connect the Printer to a Mobile Device Using NFC \(Android\)](#)

Connect the Printer to a Computer Using a USB Cable

NOTE

The USB TypeC cable is not included.

1. Make sure the printer is turned off before connecting the USB cable.
2. Connect the USB cable to the USB Port on the printer, and then to your computer.

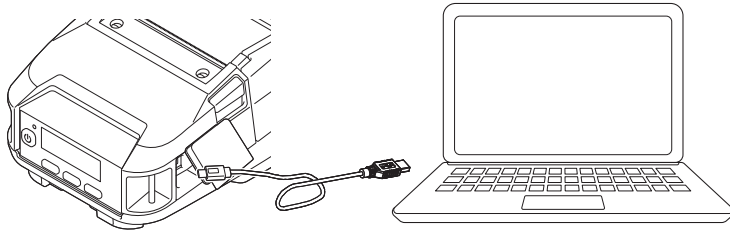

3. Turn on the printer.



Related Information

- [Connect the Printer to a Computer or Mobile Device](#)

Connect the Printer to a Computer Using Wi-Fi

Related Models: RJ-3250WB

The following Wi-Fi connection methods are available:







- >> [Using a Wi-Fi Router/Access Point \(Infrastructure Mode\)](#)
- >> [Without Using a Wi-Fi Router/Access Point \(Wireless Direct\)](#)
- >> [Using Infrastructure Mode and Wireless Direct Simultaneously](#)
- >> [Using WPS \(Wi-Fi Protected Setup™\)](#)

Using a Wi-Fi Router/Access Point (Infrastructure Mode)





Infrastructure Mode allows you to connect the printer to a computer or mobile device via Wi-Fi router/access point.

• Before You Begin

First you must configure the printer's Wi-Fi settings to communicate with your Wi-Fi router/access point. After the printer is configured, the computers and mobile devices on your network will have access to the printer.

- Before connecting the printer to your network, contact your system administrator to confirm your Wi-Fi network settings.
- To reconfigure the Wi-Fi settings, or if the status of the printer's Wi-Fi connection is unknown, reset the printer's Wi-Fi settings.
 1. Press the  (Power) button to turn off the printer.
 2. Press and hold the  (Feed) / **OK** button and the  (Power) button for about five seconds. The LED indicator starts flashing green.
 3. While pressing the  (Power) button, press the  (Feed) / **OK** button twice.
 4. Release the  (Power) button.
- To achieve the best results with normal everyday printing, use the printer as close to the Wi-Fi router/access point as possible with minimal obstructions. Large objects and walls between the two devices as well as interference from other electronic devices can affect the transfer speed of print data.

• Connect the printer to your Wi-Fi router/access point

1. First, write down the SSID (Network Name) and Password (Network Key) of your Wi-Fi router/access point.
2. Connect the printer and computer using a USB cable.
3. On the printer, press the **Menu / ▼** (Select) button to select the [WLAN] menu, and then press the  (Feed) / **OK** button. Set [On/Off] to [On].
4. Configure the Infrastructure Mode settings of the printer.
 - From the LCD menu:
 - a. Press the **Menu / ▼** (Select) button to select the [WLAN] menu, and then press the  (Feed) / **OK** button.
 - b. Press the **Menu / ▼** (Select) button to select the [Mode] menu, and then press the  (Feed) / **OK** button.
 - c. Select [Infrastructure], and then press the  (Feed) / **OK** button.
 - Using a Windows computer:
 - a. Start the Printer Setting Tool on your computer, and click the **Communication Settings** button.

- b. Select **Wireless LAN** for **Selected Interface** in the **General** tab, and select **Infrastructure** for **Communication Mode** in **Wireless Settings** in the **Wireless LAN** tab.
5. Start the Printer Setting Tool on your Windows computer, and click the **Communication Settings** button. Select **Wireless Settings** in the **Wireless LAN** tab. Enter the SSID that you wrote down, or click **Search** and select the SSID from the displayed list.
6. Enter the password as **Passphrase**.



The required information depends on the authentication method and encryption mode; enter only the information relevant to your network environment.

7. Click **Apply**.





When the connection between the printer and your Wi-Fi router/access point is established, the  (Wi-Fi) icon appears on the printer's LCD. Computers and mobile devices that are on the same network as the printer will have access to the printer.



To change any other network settings, use the Printer Setting Tool.

Without Using a Wi-Fi Router/Access Point (Wireless Direct)



Wireless Direct allows you to connect the printer to your computer or mobile device directly, without a Wi-Fi router/access point. The printer serves as a Wi-Fi access point.

1. Confirm the Wireless Direct settings of the printer.
 - From the LCD menu:
 - a. Press the **Menu / ▼** (Select) button to select the [WLAN] menu, and then press the  (Feed) / **OK** button.
 - b. Press the **Menu / ▼** (Select) button to select the [Mode] menu, and then press the  (Feed) / **OK** button.
 - c. Select [Direct], and then press the  (Feed) / **OK** button. The Wireless Direct icon appears on the LCD.
 - Using a Windows computer:
 - a. Connect the printer and computer using a USB cable.
 - b. Start the Printer Setting Tool on your computer, and click the **Communication Settings** button.
 - c. Confirm that **Wireless Direct** is selected for **Selected Interface** in the **General** tab.
2. On the printer, press the **Menu / ▼** (Select) button to select the [WLAN] menu, and then press the  (Feed) / **OK** button. Set [On/Off] to [On]
3. Use your computer or mobile device to select the SSID of the printer ("DIRECT-*****_RJ-3250WB"). If required, enter the Password ("325*****", where***** is the last five digits of the printer's serial number).

NOTE

- The serial number label is located on the base of the printer. You can also confirm the serial number by printing the printer information. For more information, see *Related Topics*.
- Use the Printer Setting Tool to change the printer's network settings.
- The Printer Setting Tool also allows you to apply the network settings to multiple printers.
- You cannot connect to the Internet via Wi-Fi while using Wireless Direct. To use the Internet, connect using a Wi-Fi router/access point (Infrastructure Mode).
- We recommend setting a new Wireless Direct password using the Printer Setting Tool to protect your printer from unauthorized access.



Using Infrastructure Mode and Wireless Direct Simultaneously

1. Set the printer to Infrastructure Mode and Wireless Direct.
 - From the LCD menu:
 - a. Press the **Menu / ▼** (Select) button to select the [WLAN] menu, and then press the  (Feed) / **OK** button.
 - b. Press the **Menu / ▼** (Select) button to select the [Mode] menu, and then press the  (Feed) / **OK** button.
 - c. Select [Direct/Infra], and then press the  (Feed) / **OK** button.
 - Using a Windows computer:
 - a. Launch the **Printer Setting Tool** on your Windows computer.
 - b. Click the **Communication Settings** button.
 - c. Click **General > Communication Settings**.
 - d. Confirm that the **Infrastructure and Wireless Direct** option is selected for the **Selected Interface** setting.

Using WPS (Wi-Fi Protected Setup™)

1. First, confirm that your Wi-Fi router/access point has the WPS symbol.



2. Place the printer within the range of your Wi-Fi router/access point.
The range may differ depending on your environment. See the instructions provided with your Wi-Fi router/access point.
3. Press the WPS button on your Wi-Fi router/access point.
4. On the printer, press the **Menu / ▼** (Select) button to select the [WLAN] menu, and then press the  (Feed) / **OK** button.
5. Press the **Menu / ▼** (Select) button to select the [WPS] menu, and then press the  (Feed) / **OK** button.
6. Select [Button Push] or [PIN Code] menu, and then press the  (Feed) / **OK** button.

For more information, see the instructions provided with your Wi-Fi router/access point. When the connection is established, the WLAN icon appears on the printer's LCD. Computers and mobile devices that are on the same network as the printer will have access to the printer.



- The printer will try to connect using WPS for two minutes. If the **Menu / ▼** (Select) button is pressed during that time, the printer will continue trying to connect for an additional two minutes.
- If your computer or mobile device supports the PIN authentication method, select [PIN Code] for better security.

Related Information



- [Connect the Printer to a Computer or Mobile Device](#)

Related Topics:

- [Change Printer Settings Using the Printer Setting Tool \(Windows\)](#)
- [Communication Settings of the Printer Setting Tool \(Windows\)](#)
- [Confirm Printer Settings](#)

Connect the Printer to a Computer Using Bluetooth Connection

Follow the manufacturer's recommendations for your Bluetooth-equipped devices (computers and mobile devices) or Bluetooth adapter, and install any necessary hardware and software.

1. Press the **Menu** / ▼ (Select) button to select the [Bluetooth] menu, and then press the  (Feed) / **OK** button.
2. Select the [On/Off] menu, and then press the  (Feed) / **OK** button. Select [On].
3. Use your Bluetooth management software to discover the printer.
Select the printer name (where XXXX is the last four digits of the printer's serial number). You can find the serial number label on the base of the printer.
Bluetooth communication is now available.

NOTE

- You can also change the printer's communication settings using the Printer Setting Tool. For more information, see *Related Information*.
- By default, Bluetooth mode is set to [Classic & LE], so two identical Bluetooth names (for Classic and Low Energy) may appear in your Android device's Bluetooth menu.
- If the passcode appears on the LCD while connecting, check that it is the same as that of the computer or mobile device, and then press the **OK** button.
- We recommend setting a new Bluetooth PIN code using the Printer Setting Tool to protect your printer from unauthorized access.



Related Information

- [Connect the Printer to a Computer or Mobile Device](#)

Related Topics:

- [Communication Settings of the Printer Setting Tool \(Windows\)](#)

Connect the Printer to a Mobile Device Using NFC (Android)

The default pairing settings will vary depending on your model and region.

1. Confirm that the printer's Bluetooth settings and the mobile device's Bluetooth and NFC settings are enabled.
2. Touch your mobile device to the printer.

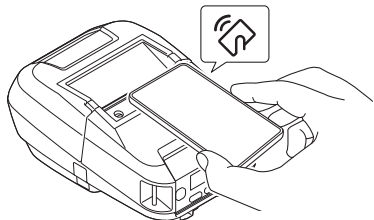

- The printer's Bluetooth mode must be set to [Classic & LE], [Classic], or [Low Energy].
- Not all Android devices may connect to your printer successfully.



Related Information

- [Connect the Printer to a Computer or Mobile Device](#)

Create and Print Labels Using Your Computer

- [Create Labels Using P-touch Editor \(Windows\)](#)
- [Print Labels Using P-touch Editor \(Windows\)](#)
- [Create Labels and Print without Installing Software and Drivers](#)
- [Print Labels Using the Printer Driver \(Windows\)](#)

Create Labels Using P-touch Editor (Windows)

To use your printer with your computer, install P-touch Editor and the printer driver.

For the latest drivers and software, go to your model's **Downloads** page on the Brother support website at support.brother.com.

1. Start the P-touch Editor .
 - **Windows 10/Windows Server 2016/Windows Server 2019:**
Click **Start > Brother P-touch > P-touch Editor**, or double-click the **P-touch Editor** icon on the desktop.
 - **Windows 8.1/Windows Server 2012/Windows Server 2012 R2:**
Click the **P-touch Editor** icon on the **Apps** screen, or double-click the **P-touch Editor** icon on the desktop.
 - **Windows 7**
Click **Start > All Programs > Brother P-touch > P-touch Editor**, or double-click the **P-touch Editor** icon on the desktop.

P-touch Editor starts.

2. Do one of the following:
 - To open an existing layout, click **Open** (1).
 - To connect a preset layout to a database, select the check box next to **Connect Database** (2).
 - To create a new layout, double-click the **New Layout** pane (3), or click the **New Layout** pane (3) and then click →.
 - To create a new layout using a preset layout, double-click a category button (4), or select a category button (4) and then click →.

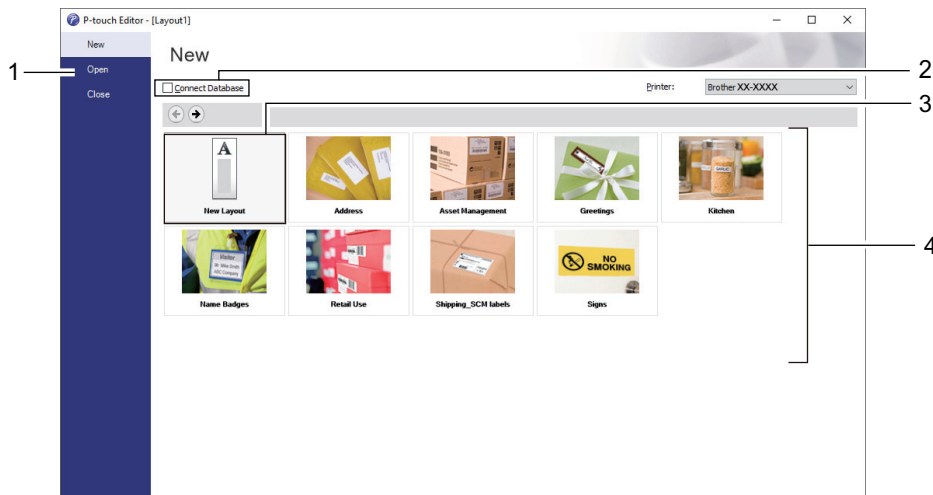

To change how P-touch Editor starts, click **Tools > Options** in the P-touch Editor menu bar to display the **Options** dialog box. On the left side, select the **General** heading, and then the setting you want in the **Operations** list box under **Startup Settings**.

✓ Related Information

- [Create and Print Labels Using Your Computer](#)
 - [Main Window of P-touch Editor Express Mode \(Windows\)](#)
 - [Main Window of P-touch Editor Professional Mode \(Windows\)](#)
 - [Main Window of P-touch Editor Snap Mode \(Windows\)](#)

Main Window of P-touch Editor Express Mode (Windows)

Express mode allows you to quickly create layouts including text and images.

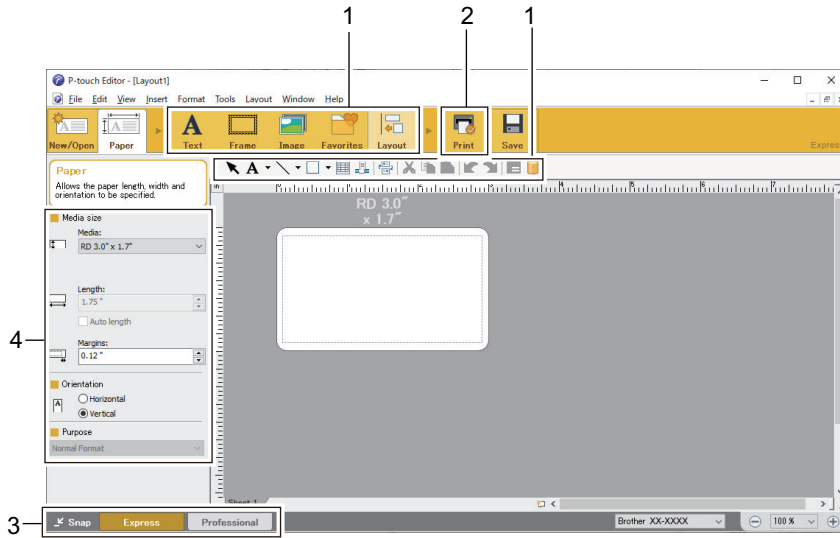

1. Edit Buttons
2. Print Button
3. Operation Mode Selection Buttons
4. Property Palettes



Related Information

- [Create Labels Using P-touch Editor \(Windows\)](#)

Main Window of P-touch Editor Professional Mode (Windows)

Professional mode allows you to create layouts using a wide-range of advanced tools and options.

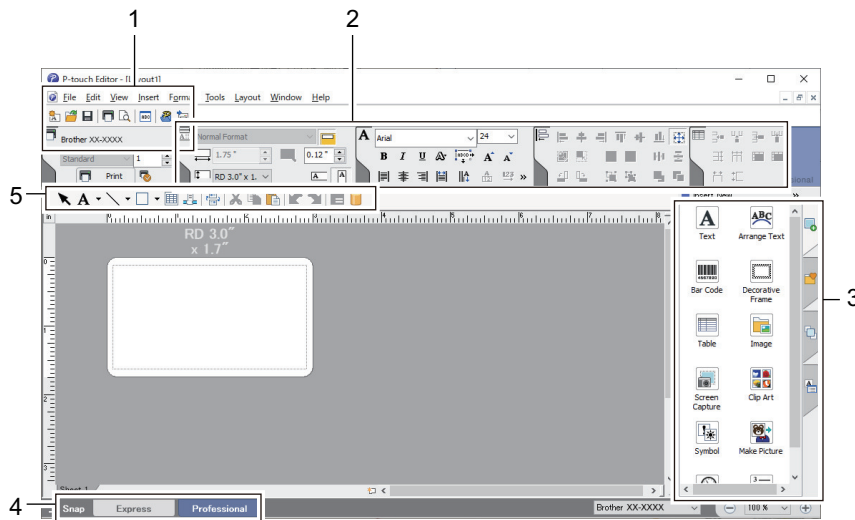

1. Print Menu
2. Property Palettes
3. Sidebar
4. Operation Mode Selection Buttons
5. Edit Toolbars

✓ Related Information

- [Create Labels Using P-touch Editor \(Windows\)](#)

Main Window of P-touch Editor Snap Mode (Windows)

Snap mode allows you to capture all or a portion of your computer screen and print it as an image.

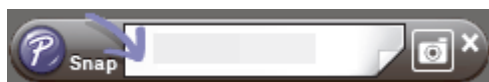
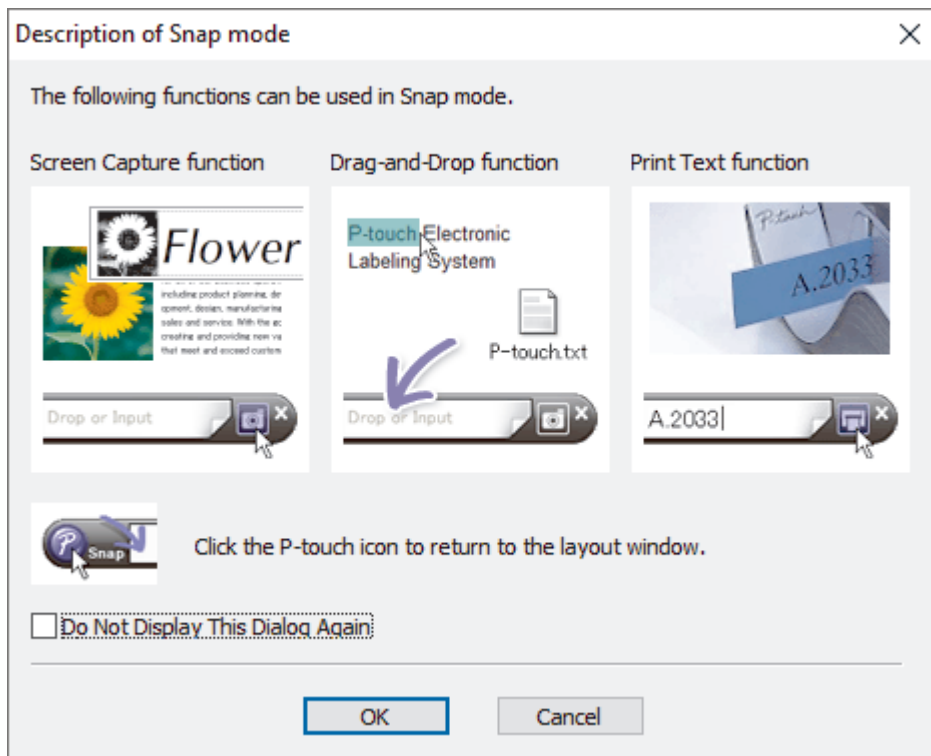

✓ Related Information

- [Create Labels Using P-touch Editor \(Windows\)](#)

Print Labels Using P-touch Editor (Windows)

- >> [Express Mode](#)
- >> [Professional Mode](#)
- >> [Snap Mode](#)

Express Mode

Configure the settings in the Print screen before printing.

- Click **File > Print** from the menu bar, or click  (**Print**).

Professional Mode

Configure the settings in the Print screen before printing.

- Click **File > Print** from the menu bar, or click .



Click  to start printing without changing the settings.

Snap Mode

- Enter the text, and then click .

✓ Related Information

- [Create and Print Labels Using Your Computer](#)
 - [Insert the Date and Time into a Label](#)

Insert the Date and Time into a Label

1. In P-touch Editor, open the label layout you want to edit.
2. Click **Insert > Date/Time** in the P-touch Editor menu bar to display the **Date and Time Properties** dialog box.
3. Select the date format you want to use.

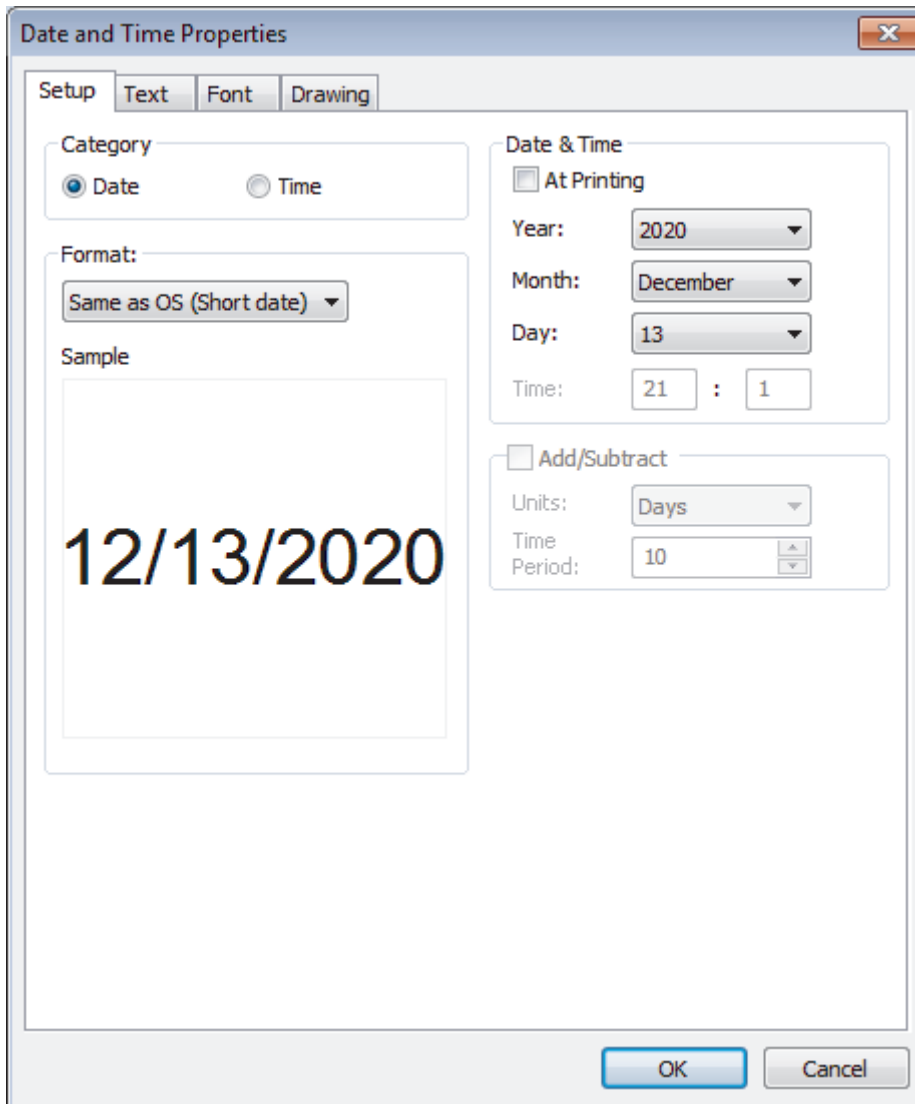

 The date and time inserted into the label will be printed using the printer's default character size. Because the character size is determined by the size of the date and time object, adjust the object to the size you want in P-touch Editor before transferring the label layout to the printer.

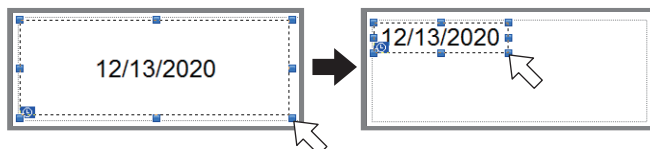

Related Information

- [Print Labels Using P-touch Editor \(Windows\)](#)

Create Labels and Print without Installing Software and Drivers

- [Print Using the USB Interface \(Mass Storage Mode\)](#)
- [Print Image Data without Using the Printer Driver](#)

Print Using the USB Interface (Mass Storage Mode)

The mass storage feature allows you to send a file to the printer using the USB interface, without installing the printer driver.

This feature is useful for:

- Applying printer settings saved in a command file (BIN file format) and adding templates (BLF file format) into your printer without using any software tools. Both types of files must be distributed by an administrator.
- Executing commands without installing the printer driver.
- Using a device with an operating system (including non-Windows operating systems) supporting a USB host feature to print and transmit data.

1. Confirm that the printer is turned off.

2. While pressing the **Menu / ▼** (Select) button, press and hold and the  (Power) button.

The printer starts up in mass storage mode. The message [Mass Storage] appears on the LCD.

3. Connect the computer or mobile device to the printer using a USB cable.

The printer's mass storage area appears as a folder on the computer's or device's screen.



If the mass storage area does not appear automatically, see the instructions for the operating system of your computer or mobile device for information about accessing the mass storage area.

4. Drag and drop the file you want to copy to the mass storage area.

5. Press the **Menu / ▼** (Select) button.

The command file is executed. The message [Receiving] appears on the LCD.

6. After the file has been executed, the message [Mass Storage] appears on the LCD.

7. To turn off mass storage mode, turn off the printer.

The printer will start up in its normal operating mode.

NOTE

- When the printer is turned off, mass storage mode is deactivated and any files in the mass storage area are deleted.
- This feature supports only BIN, BLF, and JPG files.
- Do not create folders in the mass storage area. If a folder is created, the files in the folder cannot be accessed.
- The capacity of the mass storage area is 15.8 MB.
- If multiple files are copied, the commands may not be executed.
- Only the USB connection is available while the printer is in mass storage mode.
- Do not access other files in the mass storage area when executing a copied file.



Related Information

- [Create Labels and Print without Installing Software and Drivers](#)

Print Image Data without Using the Printer Driver



- The mass storage mode supports the JPEG image printing.
- The Object Push Profile (OPP) is used for printing via Bluetooth connection.
- The printer converts a color JPEG image to a black and white image using a dithering process.
- When sending a black and white JPEG image, the dithering process may produce a fuzzy image.
- To improve the image quality, try to turn off any preprocessing of the JPEG image.

- Only JPEG images can be printed. (Limited to files with the .jpg extension.)
- The maximum file size is 15.8 MB.
- The maximum resolution is as follows:
 - Height × Width = 24000 dots × 576 dotsIf these limits are exceeded, the data received by the printer is discarded and not printed.
- Print is at 1 pixel = 1 dot.
- The printer performs binary processing (simple binary) to print the image.
- The image is printed with the height-to-width proportions of the received data.



Related Information

- [Create Labels and Print without Installing Software and Drivers](#)

Print Labels Using the Printer Driver (Windows)

1. Connect the printer to a computer.
2. Open the document you want to print.
3. Select the print command in your application.
4. Select your printer, and then click the printing properties or preferences button.
The printer driver window appears.
5. Change the printer driver settings, if needed.
6. Click **OK**.
7. Complete your print operation.



Related Information

- [Create and Print Labels Using Your Computer](#)
-

Print Labels Using Mobile Devices

- [Available Software](#)
- [AirPrint Overview](#)
- [Transfer Templates Created on a Computer to the Printer Using a Mobile Device](#)

Available Software

(RJ-3250WB) Brother offers various applications for use with your printer, including applications to print directly from your iPhone, iPad, iPod touch, and Android™ mobile devices, and applications to transfer data wirelessly, such as templates, symbols, and databases created using a computer, to your stand-alone printer.

(RJ-3230B) Brother offers various applications for use with your printer, including applications to print directly from your iPhone, iPad, iPod touch, and Android™ mobile devices.

For more information about the mobile applications available for your printer, visit <https://support.brother.com/g/d/f5f9>.

Apple Devices

Software	Features
Print SDK	Download the Software Development Kit (SDK) from the Brother Developer Center (https://support.brother.com/g/s/es/dev/en/index.html).
Mobile Transfer Express	This application allows you to use a mobile device to download databases and label data, which were created on a computer using P-touch Editor and saved to a cloud service, and send them to your printer. Download this free Brother app from the App Store.
AirPrint (RJ-3250WB)	Allows you to print from an Apple device (iPad, iPhone, or iPod touch) without installing additional software.
Mobile Deploy	Allows you to perform updates for the settings and firmware of printers using a mobile device. This software will send printer update files uploaded to DropBox or an HTTP(S) server to target printers. Download this free Brother app from the App Store.

Android Devices

Software	Features
Print SDK	Download the Software Development Kit (SDK) from the Brother Developer Center (https://support.brother.com/g/s/es/dev/en/index.html).
Mobile Transfer Express	This application allows you to use a mobile device to download databases and label data, which were created on a computer using P-touch Editor and saved to a cloud service, and send them to your printer. Download this free Brother app from Google Play™.
Print Service Plugin	Allows you to print from an Android device without installing additional software.
Mobile Deploy	Allows you to perform updates for the settings and firmware of printers using a mobile device. This software will send printer update files uploaded to DropBox or an HTTP(S) server to target printers. Download this free Brother app from Google Play™.



Related Information

- [Print Labels Using Mobile Devices](#)

AirPrint Overview

Related Models: RJ-3250WB

AirPrint is a printing solution for Apple operating systems that allows you to wirelessly print photos, email, web pages and documents from your iPad, iPhone and iPod touch without the need to install a driver.

For more information, visit Apple's website.

Use of the Works with Apple badge means that an accessory has been designed to work specifically with the technology identified in the badge and has been certified by the developer to meet Apple performance standards.



Related Information

- [Print Labels Using Mobile Devices](#)

Transfer Templates Created on a Computer to the Printer Using a Mobile Device

Make sure Mobile Transfer Express is installed on your mobile device.

Use P-touch Transfer Manager to save template data created using P-touch Editor in either BLF or PDZ format. Use Mobile Transfer Express to send the saved file from your mobile device to the printer and print it.

1. Save the template data using P-touch Transfer Manager.



For more information, see [Related Information](#).

2. Do one of the following:
 - Save the file using a cloud storage service, and then use the sharing function of the mobile device to share the file.
 - Send the file as an email attachment from the computer to the mobile device, and then save the file to the mobile device.
3. Connect the printer to your mobile device, and then start Mobile Transfer Express.
The template data appears.
4. Select the template you want to print, and then transfer the template to the printer.



To download a file from a cloud storage service to your mobile device, you must connect your mobile device using Infrastructure Mode. By connecting your mobile device to the printer using Infrastructure Mode, you can also quickly transfer downloaded files (BLF files only).



Related Information

- [Print Labels Using Mobile Devices](#)

Related Topics:

- [Create Transfer Files and Transfer Package Files \(Windows\)](#)
- [Connect the Printer to a Computer Using Wi-Fi](#)

Transfer Templates to the Printer (P-touch Transfer Manager) (Windows)

- [Transfer Templates to the Printer Using P-touch Transfer Manager \(Windows\)](#)
- [Distribute Templates to be Transferred to Users Without Using P-touch Transfer Manager \(Windows\)](#)

Transfer Templates to the Printer Using P-touch Transfer Manager (Windows)

- [Notes on Using P-touch Transfer Manager \(Windows\)](#)
- [Transfer Templates from the Computer to the Printer \(Windows\)](#)
- [Back up Templates or Other Data Saved in the Printer \(Windows\)](#)
- [Delete Printer Data \(Windows\)](#)
- [Create Transfer Files and Transfer Package Files \(Windows\)](#)

Notes on Using P-touch Transfer Manager (Windows)

Because some P-touch Editor functions are not available with the printer, keep the following points in mind when using P-touch Editor to create templates.

You can check a preview of the printed template before the created template is transferred to the printer.

Creating Templates

- Some of the text in the template transferred to the printer may be printed using similar fonts and character sizes loaded in the printer. As a result, the printed label may differ from the image of the template created in P-touch Editor.
- Depending on the text object setting, the character size may be automatically reduced or some of the text may not be printed. If this occurs, change the text object setting.
- Although character styles can be applied to individual characters with P-touch Editor, styles can be applied to a block of text only with the printer. In addition, some character styles are not available on the printer.
- Backgrounds specified with P-touch Editor are not compatible with the printer.
- The P-touch Editor layout using the split printing function (enlarging the label and printing it on two or more labels) cannot be transferred.
- Only the portion of the label within the printable area is printed.
- Fields overflowing the print area may not be printed completely.

Transferring Templates

- The printed label may differ from the image appearing in the preview area of P-touch Transfer Manager.
- If a two dimensional barcode not loaded on the printer is transferred to the printer, the barcode is converted into an image. The image of the converted barcode cannot be edited.
- All transferred objects that cannot be edited by the printer are converted into images.
- Grouped objects are converted into a single bitmap.

Transferring Data Other Than Templates

- If the number or order of fields in a database is changed and only the database (CSV file) is transferred to update it, the database may not link correctly with the template. In addition, the first line of data in the transferred file must be recognized by the printer as "field names."
- Logos, symbols, and graphics downloaded to the printer are automatically scaled to the resident font or any of the resident symbols in the library.



Related Information

- [Transfer Templates to the Printer Using P-touch Transfer Manager \(Windows\)](#)

▲ [Home](#) > [Transfer Templates to the Printer \(P-touch Transfer Manager\) \(Windows\)](#) > [Transfer Templates to the Printer Using P-touch Transfer Manager \(Windows\)](#) > [Transfer Templates from the Computer to the Printer \(Windows\)](#)

Transfer Templates from the Computer to the Printer (Windows)

You can transfer templates and other data to the printer and save backups of your data on the computer.

To use P-touch Transfer Manager, you must first transfer templates created in P-touch Editor to P-touch Transfer Manager.



Related Information

- [Transfer Templates to the Printer Using P-touch Transfer Manager \(Windows\)](#)
 - [Transfer the Template to P-touch Transfer Manager \(Windows\)](#)
 - [Main Window of P-touch Transfer Manager \(Windows\)](#)
 - [Transfer Templates or Other Data from the Computer to the Printer \(Windows\)](#)

Transfer the Template to P-touch Transfer Manager (Windows)

1. Start the P-touch Editor .
 - **Windows 10/Windows Server 2016/Windows Server 2019:**
Click **Start > Brother P-touch > P-touch Editor**, or double-click the **P-touch Editor** icon on the desktop.
 - **Windows 8.1/Windows Server 2012/Windows Server 2012 R2:**
Click the **P-touch Editor** icon on the **Apps** screen, or double-click the **P-touch Editor** icon on the desktop.
 - **Windows 7**
Click **Start > All Programs > Brother P-touch > P-touch Editor**, or double-click the **P-touch Editor** icon on the desktop.

P-touch Editor starts.

2. Open the template you want or create a label layout.
3. Click **File > Transfer Template > Transfer**.

The P-touch Transfer Manager window appears. A template is transferred to the **Configurations** folder.

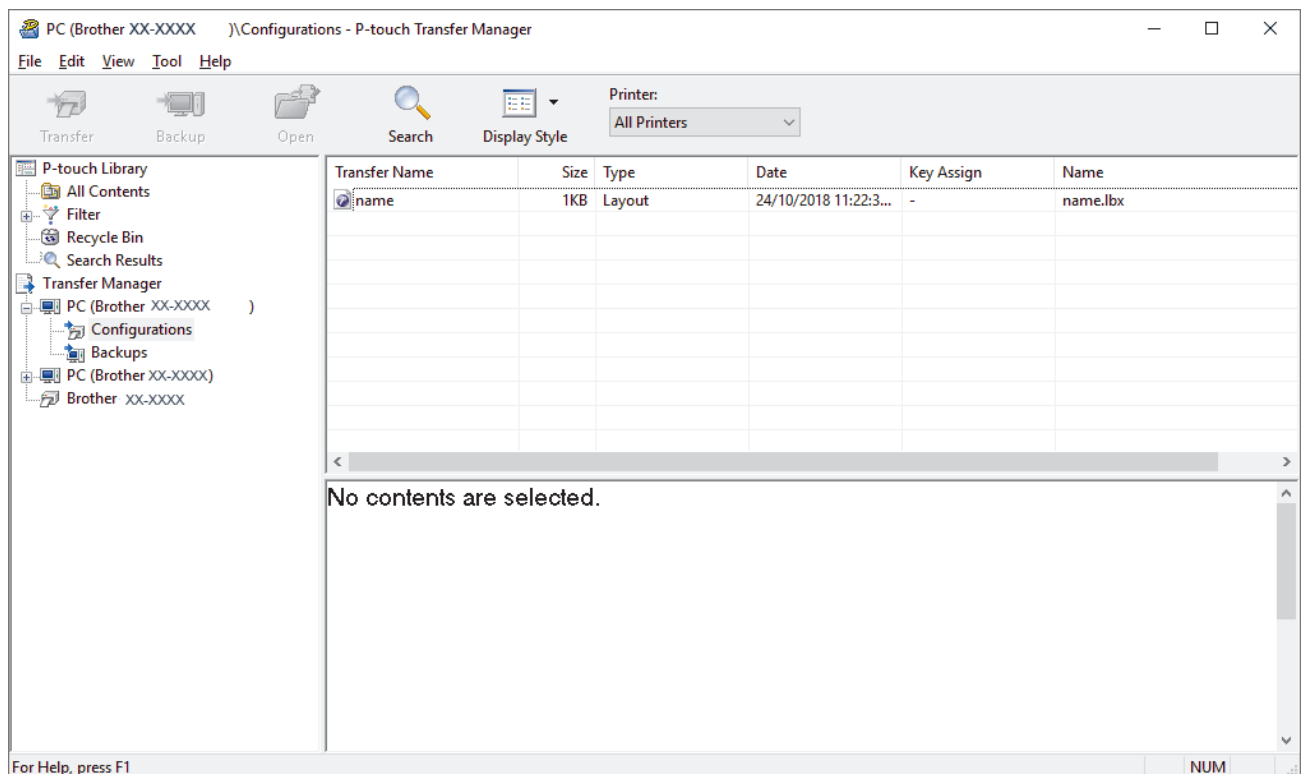

✓ Related Information

- [Transfer Templates from the Computer to the Printer \(Windows\)](#)

Main Window of P-touch Transfer Manager (Windows)

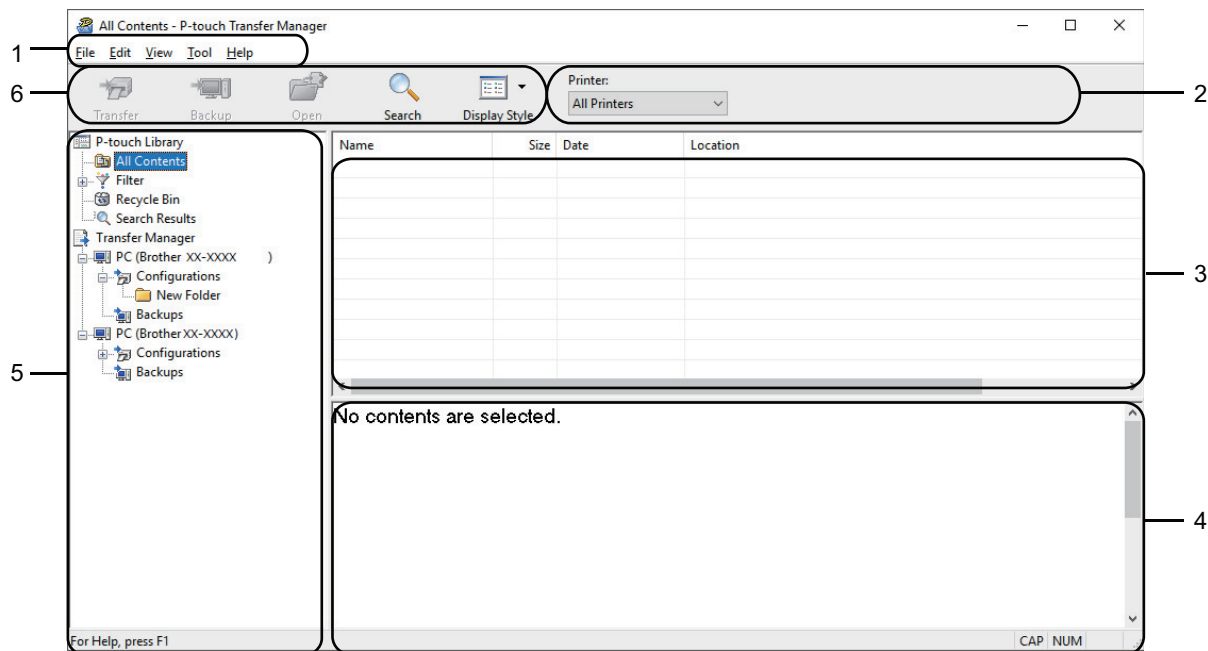

1. Menu Bar

Provides access to various commands grouped under each menu title (the **File**, **Edit**, **View**, **Tool**, and **Help** menus) according to their functions.

2. Printer Selector

Allows you to select a printer to transfer the data to. When you select a printer, only the data that can be sent to the selected printer appears in the data list.

3. Template List

Displays a list of templates in the selected folder.

4. Preview

Displays a preview of the templates in the templates list.

5. Folder List





Displays a list of folders and printers. When you select a folder, the templates in the selected folder appear in the template list. If you select a printer, the current templates and other data stored in the printer appear.

6. Toolbar

Provides access to frequently used commands.

Toolbar Icons

Icon	Button name	Function
	Transfer	Transfers templates and other data from the computer to the printer.
	Save Transfer File (When not connected to a printer)	Changes the file type of the data to be transferred to other applications. Select BLF for the filename extension when printing labels using Mass Storage Mode (USB), or when transferring the data using BRAdmin Professional (LAN or Wi-Fi) or Mobile Transfer Express (Wi-Fi). Select PDZ when transferring the data using Transfer Express (USB). The available interfaces may differ depending on your model.

Icon	Button name	Function
	Backup	Retrieves the templates and other data saved in the printer and saves it on the computer.
	Open	Opens the selected template.
	Search	Allows you to search for templates or other data registered to P-touch Library.
	Display Style	Changes the file display style.



Related Information

- [Transfer Templates from the Computer to the Printer \(Windows\)](#)
-

Transfer Templates or Other Data from the Computer to the Printer (Windows)



To transfer templates from a mobile device to the printer, see *Related Information*.

1. Connect the printer and the computer using a USB cable, and then turn on the printer.
The printer model name appears next to a printer icon in the folder view.
If you select the printer in the folder view, the current templates and other data stored in the printer appear.



If a printer is disconnected or offline, it does not appear in the folder view.

2. Select the printer you want to transfer the template or other data to.

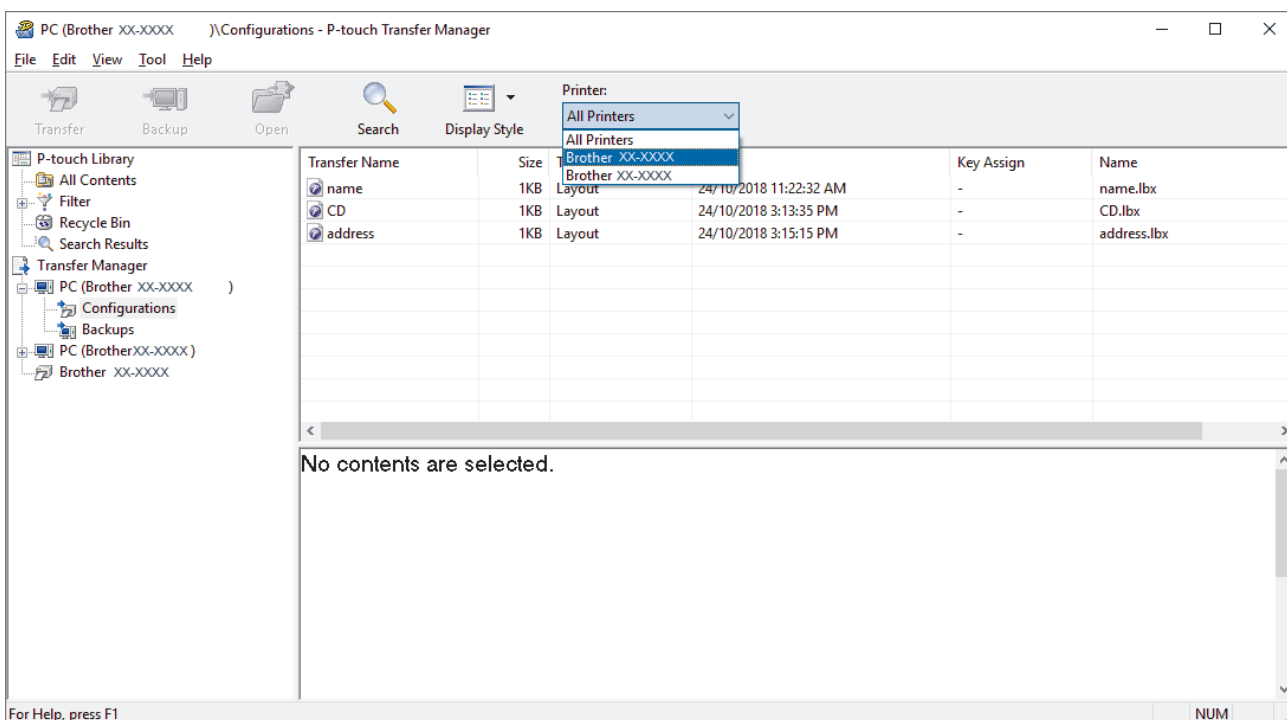

3. Right-click the **Configurations** folder, select **New**, and then create a new folder.

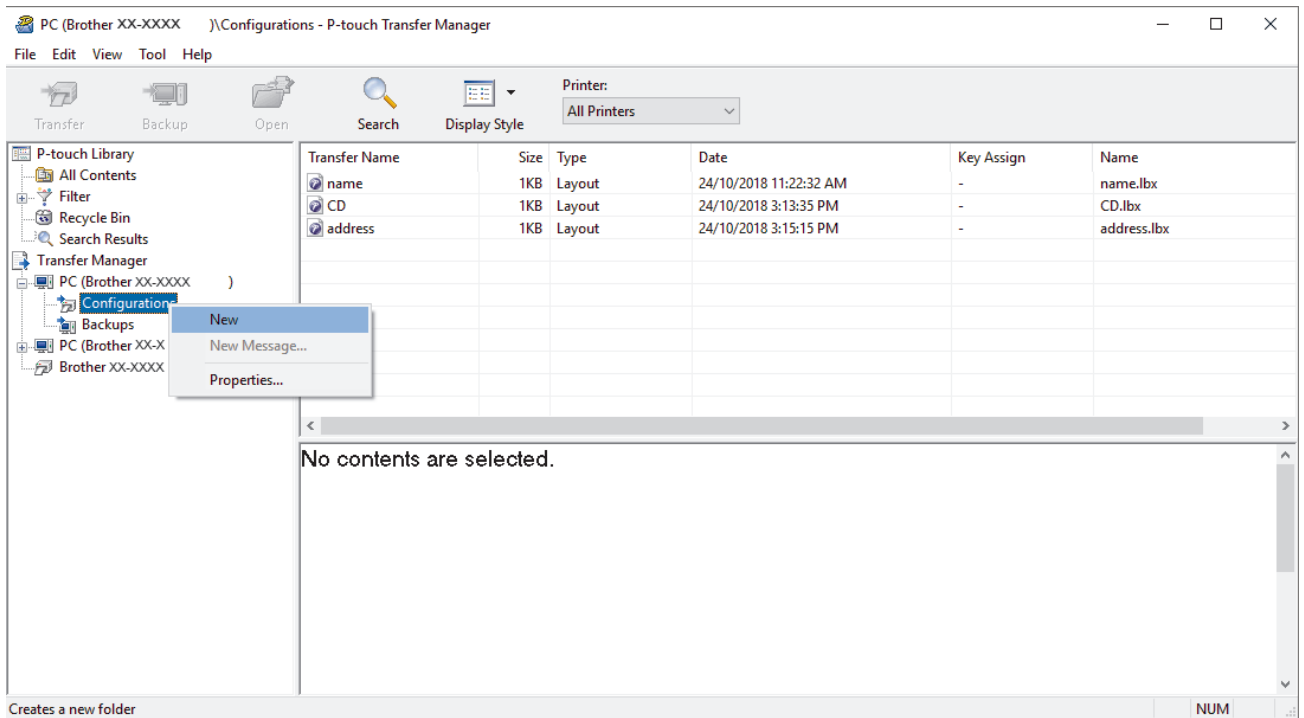

4. Do one of the following:

- Drag the template or other data you want to transfer and place it in the new folder.
- To transfer multiple templates or other data, drag the files you want to transfer, and then place them in the new folder. Each file is assigned a Key Assign number (memory location in the printer) when it is placed in the new folder.

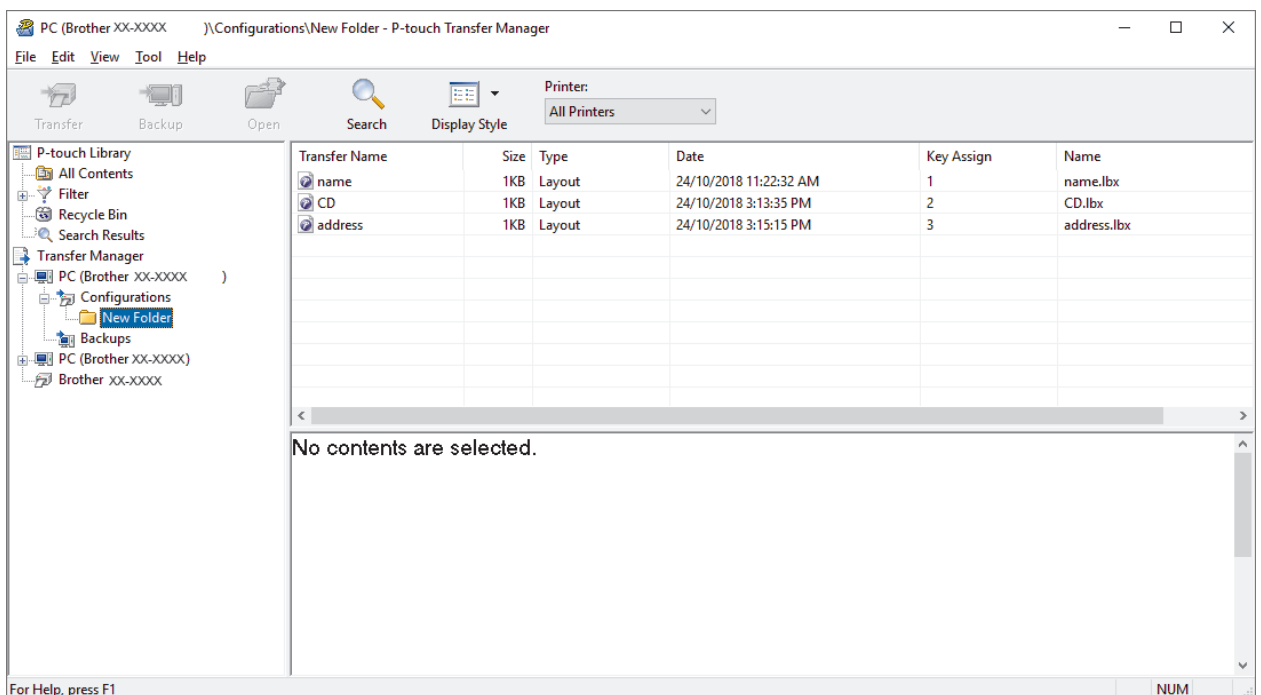

Data type	Maximum number of transferable items	Restriction details
Template	255	Each template can contain a maximum of 255 objects.
Database	255	<ul style="list-style-type: none"> • Only CSV files can be transferred. • Each CSV file can contain a maximum of 65000 records.
Image (transferred symbols)	255	<ul style="list-style-type: none"> • Only BMP files can be transferred. • Monochrome BMP files are recommended. • The size limit is 832 pixels x 832 pixels.

Data type	Maximum number of transferable items	Restriction details
		<ul style="list-style-type: none"> Wide images may be cropped.



- You can confirm the available space in the transfer file memory by printing the Printer Setting Report. See **Available memory** in the report for the available space. The available space appearing in **Available memory: ****B** may be different from the actual available space.
- You can view the templates and other data by selecting:
 - The folder in the **Configurations** folder
 - All Contents**
 - One of the categories under **Filter**, such as **Layouts**

5. To change the Key Assign number assigned to an item, right-click the item, select the **Key Assign** menu, and then select the Key Assign number you want.

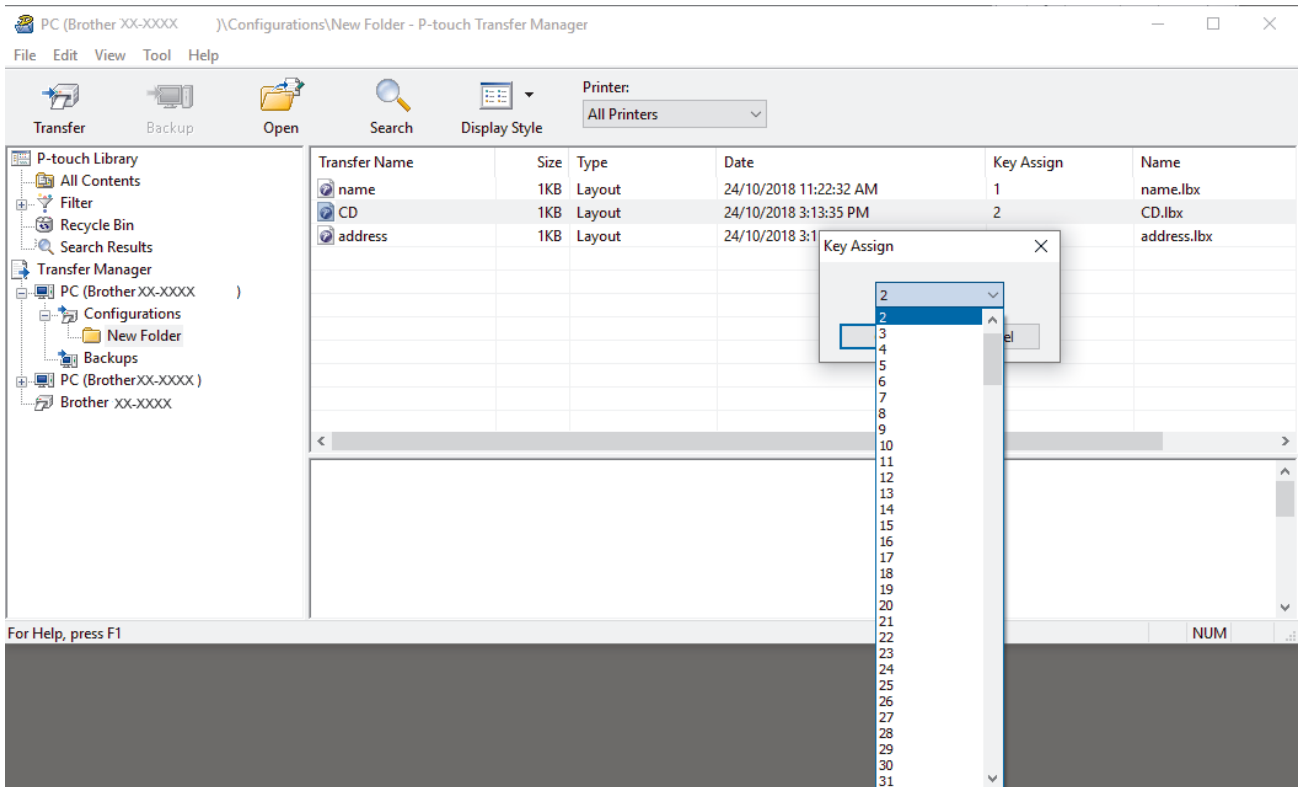

- Except for the data in databases, all data transferred to the printer is assigned a key number.
- If the template or other data transferred to the printer has the same key number as another template already saved in the printer, the new template overwrites the old one. You can confirm the assigned template numbers saved in the printer by backing up the templates or other data.
- If the printer memory is full, remove one or more templates from the printer's memory.

6. To change the template names or other data you want to transfer, click the item you want, and then type the new name.

The number of characters used for the template names may be limited depending on the printer model.

7. Select the folder containing the templates or other data you want to transfer, and then click **Transfer**.

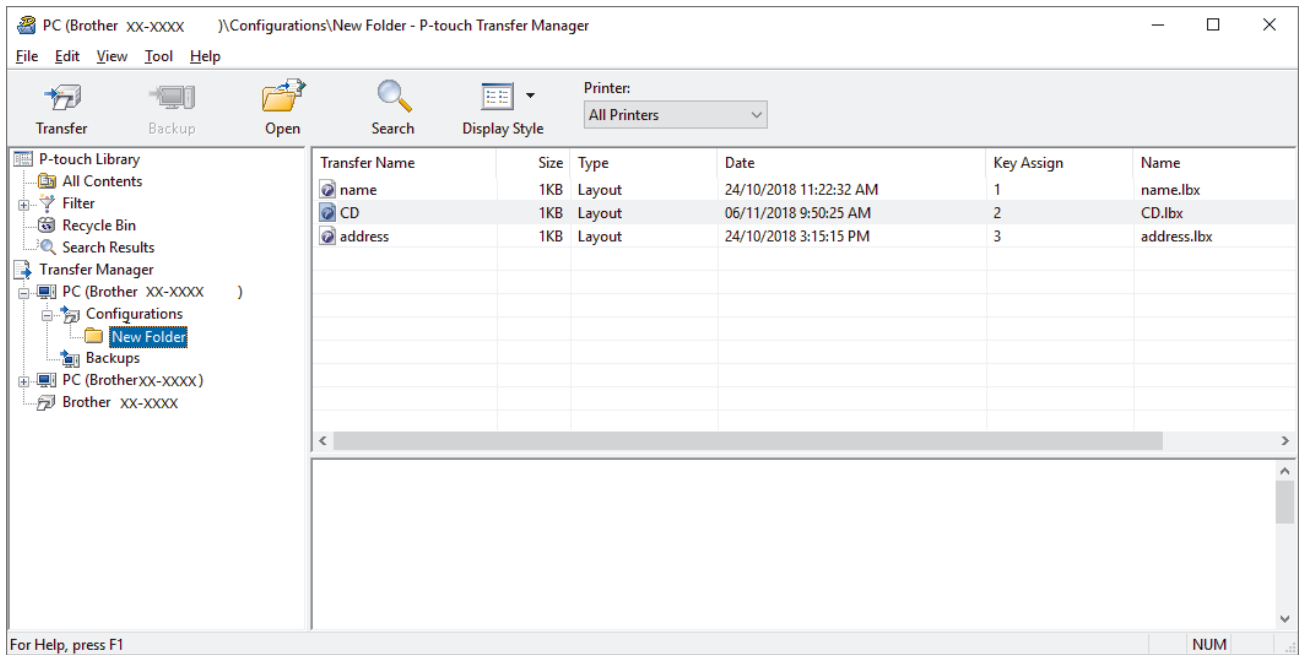

A confirmation message appears.



- You can also transfer individual items to the printer without adding them to a folder. Select the template or other data you want to transfer, and then click **Transfer**.
- Multiple items and folders can be selected and transferred in one operation.

8. Click **OK**.

The selected items are transferred to the printer.



Related Information

- [Transfer Templates from the Computer to the Printer \(Windows\)](#)

Related Topics:

- [Transfer Templates Created on a Computer to the Printer Using a Mobile Device](#)

Back up Templates or Other Data Saved in the Printer (Windows)



- Backed up templates or other data cannot be edited on the computer.
- Depending on the printer model, backed up templates or data may not be transferable between different models.

1. Connect the computer and the printer and turn on the printer.

The printer model name appears next to a printer icon in the folder view. If you select the printer in the folder view, the current templates and other data stored in the printer appear.

2. Select the printer to back up from, and then click **Backup**.

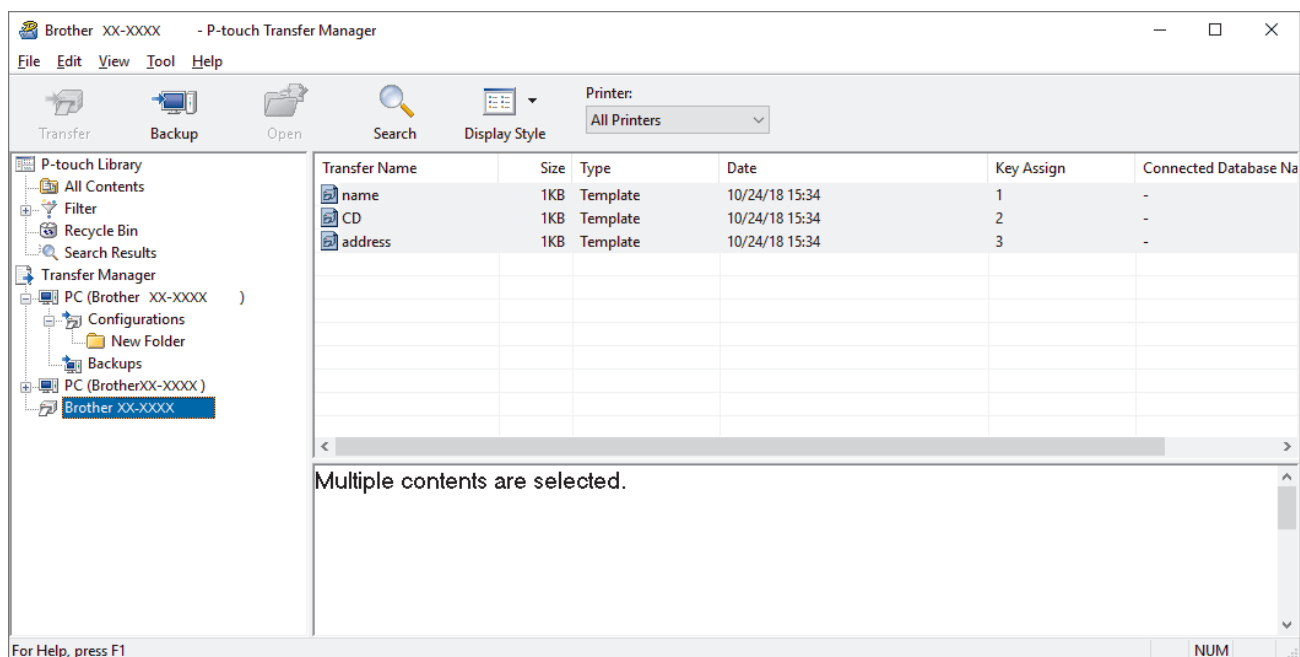

A confirmation message appears.

3. Click **OK**.

A new folder is created under the printer in the folder view. The folder name is based on the date and time of the backup. All of the printer's templates and other data are transferred to the new folder and saved on the computer.



Related Information

- [Transfer Templates to the Printer Using P-touch Transfer Manager \(Windows\)](#)

Delete Printer Data (Windows)

To delete all templates and other data saved on the printer, do the following:

1. Connect the computer and the printer and turn on the printer.
The printer model name appears next to a printer icon in the folder view.
2. Right-click the printer, and then select the **Delete All** menu.

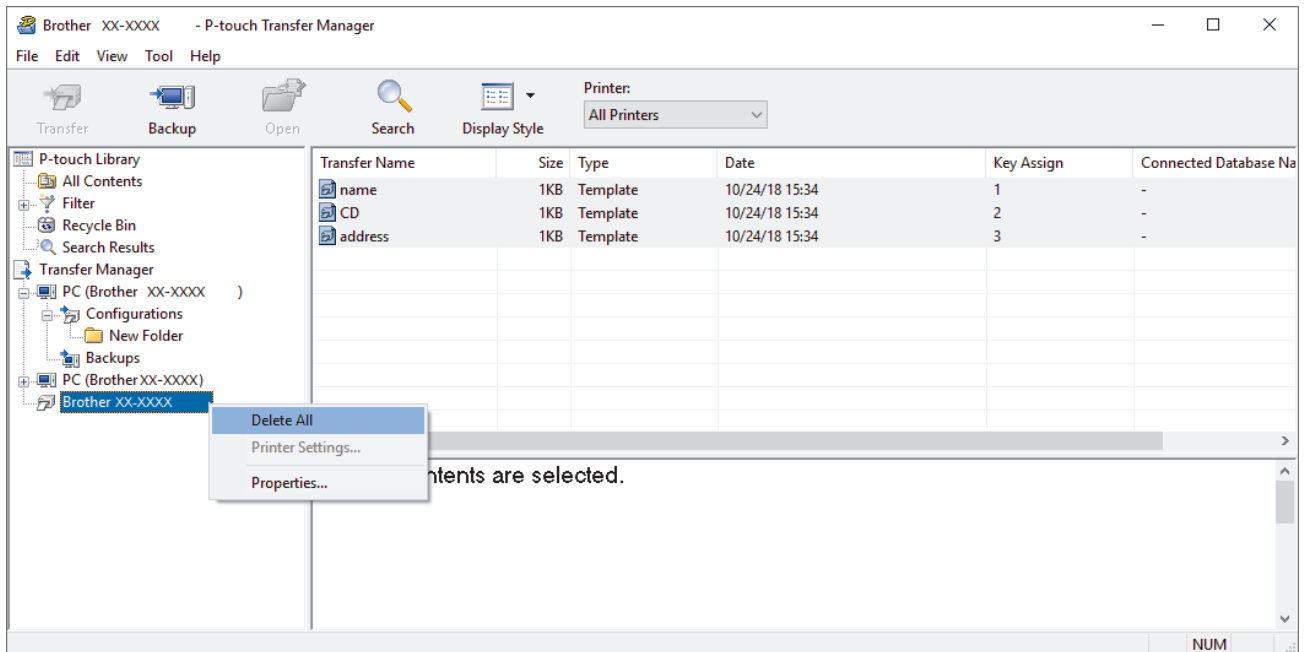

A confirmation message appears.

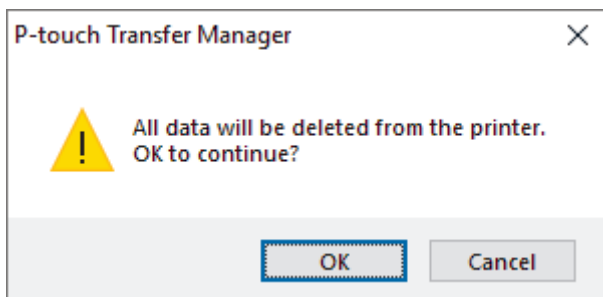

3. Click **OK**.
All templates and other data saved on the printer are deleted.

✓ Related Information

- [Transfer Templates to the Printer Using P-touch Transfer Manager \(Windows\)](#)

Create Transfer Files and Transfer Package Files (Windows)

Use P-touch Transfer Manager to save template data created using P-touch Editor in BLF or PDZ format, and transfer the files in this format to a printer from a computer or mobile device.

You can also print files in the BLF format using mass storage mode.

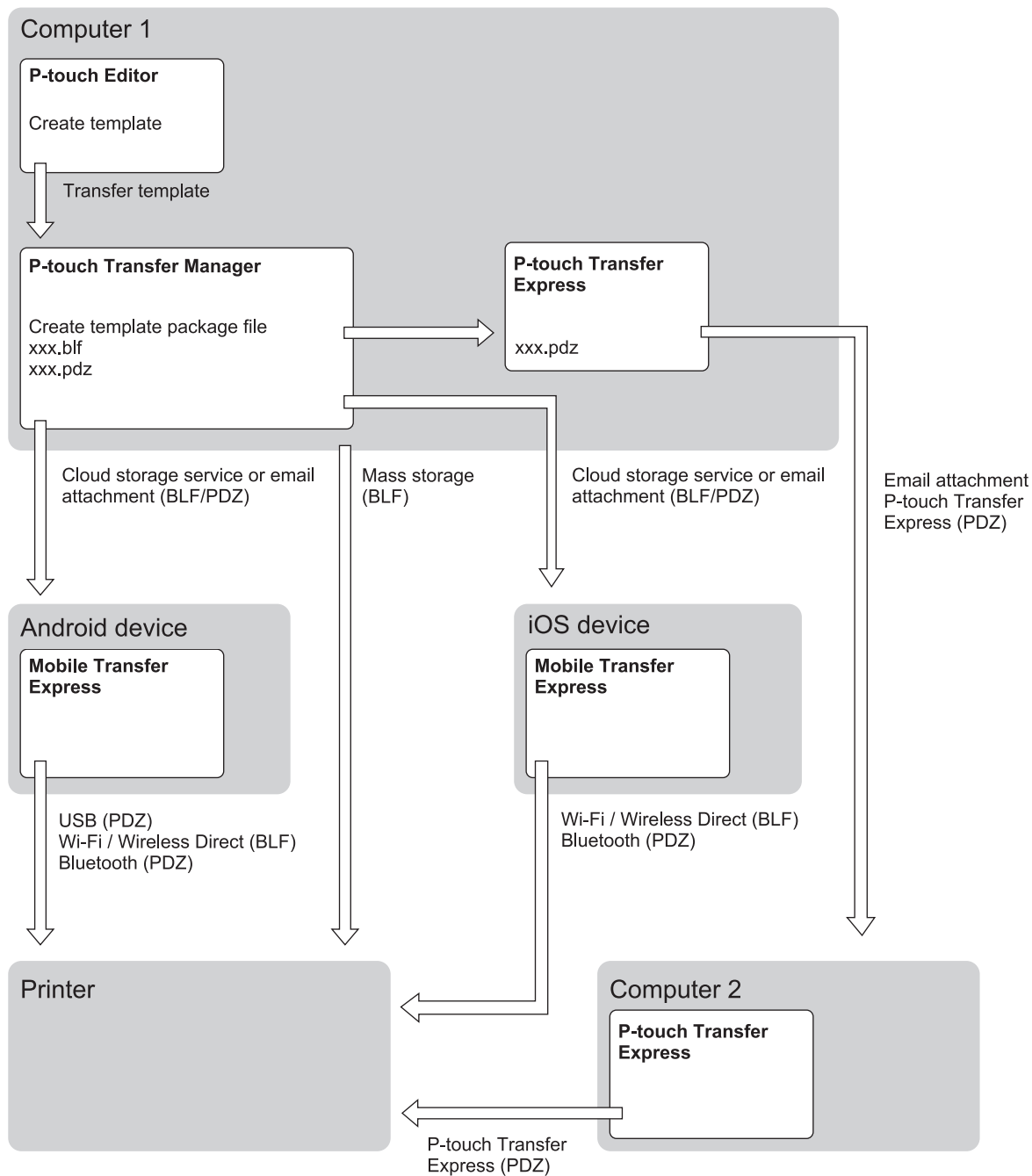

Template Transfer Method		File Format
From a mobile device (Using Mobile Transfer Express)	via USB	PDZ
	via Wi-Fi (RJ-3250WB)	BLF
	via Wireless Direct (RJ-3250WB)	BLF

Template Transfer Method		File Format
	via Bluetooth	PDZ
	Mass storage	BLF
From a computer	P-touch Transfer Express	PDZ
	Mass storage	BLF

1. Create the template using P-touch Editor, and then transfer it to P-touch Transfer Manager.



- For more information, see *Related Information*.
- When transferring a new template, make sure you specify a Key Assign number (in P-touch Transfer Manager) that is not currently used. If the specified Key Assign number is already being used, the existing template will be overwritten with the new one.

2. Without connecting the printer to the computer, select the **Configurations** folder in the P-touch Transfer Manager window, and then select the template to save.



You can select multiple templates at the same time.

3. Click **File > Save Transfer File**.

NOTE

The **Save Transfer File** button appears when the printer is disconnected from the computer or offline.



- If you click the **Save Transfer File** button after selecting **Configurations**, all templates in the folder are saved as the Transfer file (BLF) or Transfer Package file (PDZ).
- You can combine multiple templates into a single Transfer file (BLF) or Transfer Package file (PDZ).

4. In the **Save as type** field, select the template format you want, and then type in the name and save the template.



Related Information

- [Transfer Templates to the Printer Using P-touch Transfer Manager \(Windows\)](#)

Related Topics:

- [Transfer the Template to P-touch Transfer Manager \(Windows\)](#)

Distribute Templates to be Transferred to Users Without Using P-touch Transfer Manager (Windows)

Transfer templates to the printer using P-touch Transfer Express.

To download the latest version of P-touch Transfer Express, go to your model's **Downloads** page on the Brother support website at support.brother.com.



- When transferring a new template, make sure you specify a Key Assign number (in P-touch Transfer Manager) that is not currently used. If the specified Key Assign number is already being used, the existing template will be overwritten with the new one.
- This function requires a USB connection.

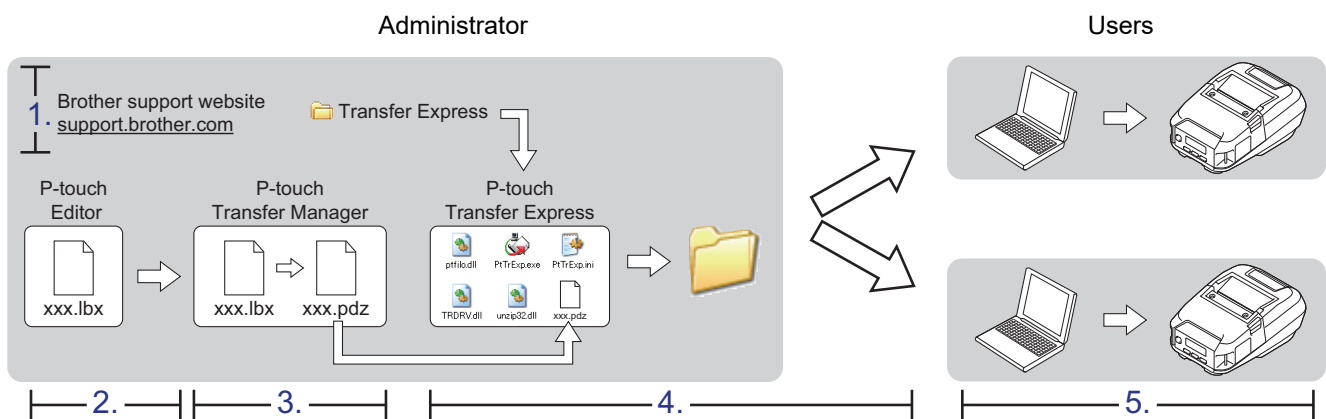

- >> [Administrator Tasks](#)
- >> [User Tasks](#)

Administrator Tasks

- >> [Preparing P-touch Transfer Express](#)
- >> [Transfer the Template to P-touch Transfer Manager](#)
- >> [Save the Template as a Transfer Package File \(PDZ\)](#)
- >> [Distribute the Transfer Package File \(PDZ\) and P-touch Transfer Express to Others](#)

Preparing P-touch Transfer Express

The printer driver must be installed before using P-touch Transfer Express.



P-touch Transfer Express is available only in English.

1. Download P-touch Transfer Express to any location on the computer.
2. Decompress the downloaded file (ZIP).

Transfer the Template to P-touch Transfer Manager

1. Start the P-touch Editor .
 - **Windows 10/Windows Server 2016/Windows Server 2019:**
Click **Start** > **Brother P-touch** > **P-touch Editor**, or double-click the **P-touch Editor** icon on the desktop.
 - **Windows 8.1/Windows Server 2012/Windows Server 2012 R2:**
Click the **P-touch Editor** icon on the **Apps** screen, or double-click the **P-touch Editor** icon on the desktop.

- **Windows 7**

Click **Start > All Programs > Brother P-touch > P-touch Editor**, or double-click the **P-touch Editor** icon on the desktop.

P-touch Editor starts.

2. Open the template you want.
3. Click **File > Transfer Template > Transfer**.

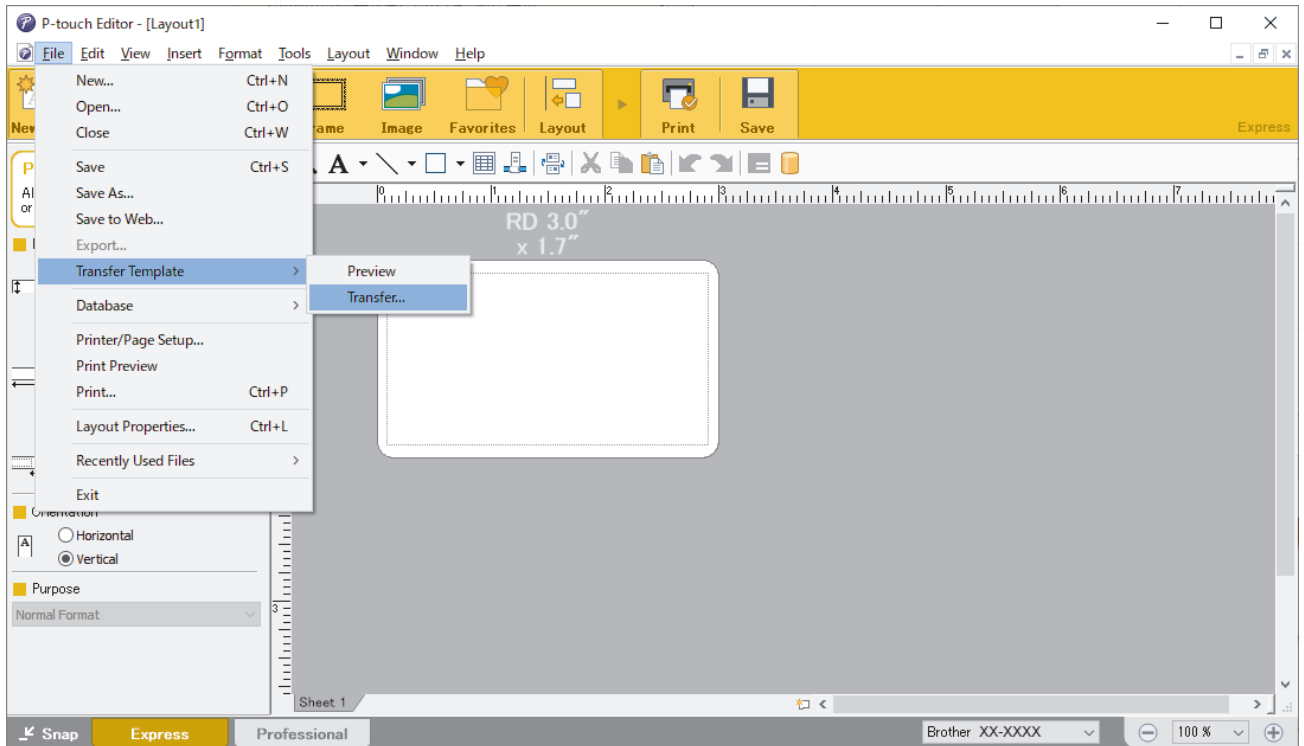

The template is transferred to P-touch Transfer Manager. P-touch Transfer Manager starts.

Save the Template as a Transfer Package File (PDZ)

To create a file in a format that can be used by P-touch Transfer Express, save the template as a Transfer Package file (PDZ).

1. Select the **Configurations** folder in the P-touch Transfer Manager window.
2. Select the templates you want to distribute.
3. Click **File > Save Transfer File**.



- The **Save Transfer File** option appears only if the printer is disconnected from the computer or offline.
- If you click the **Save Transfer File** option after selecting the **Configurations** folder or a created folder, all templates in the folder are saved as the Transfer Package file (PDZ).
- You can combine multiple templates into a single Transfer Package file (PDZ).

4. Type the name, and then click **Save**.

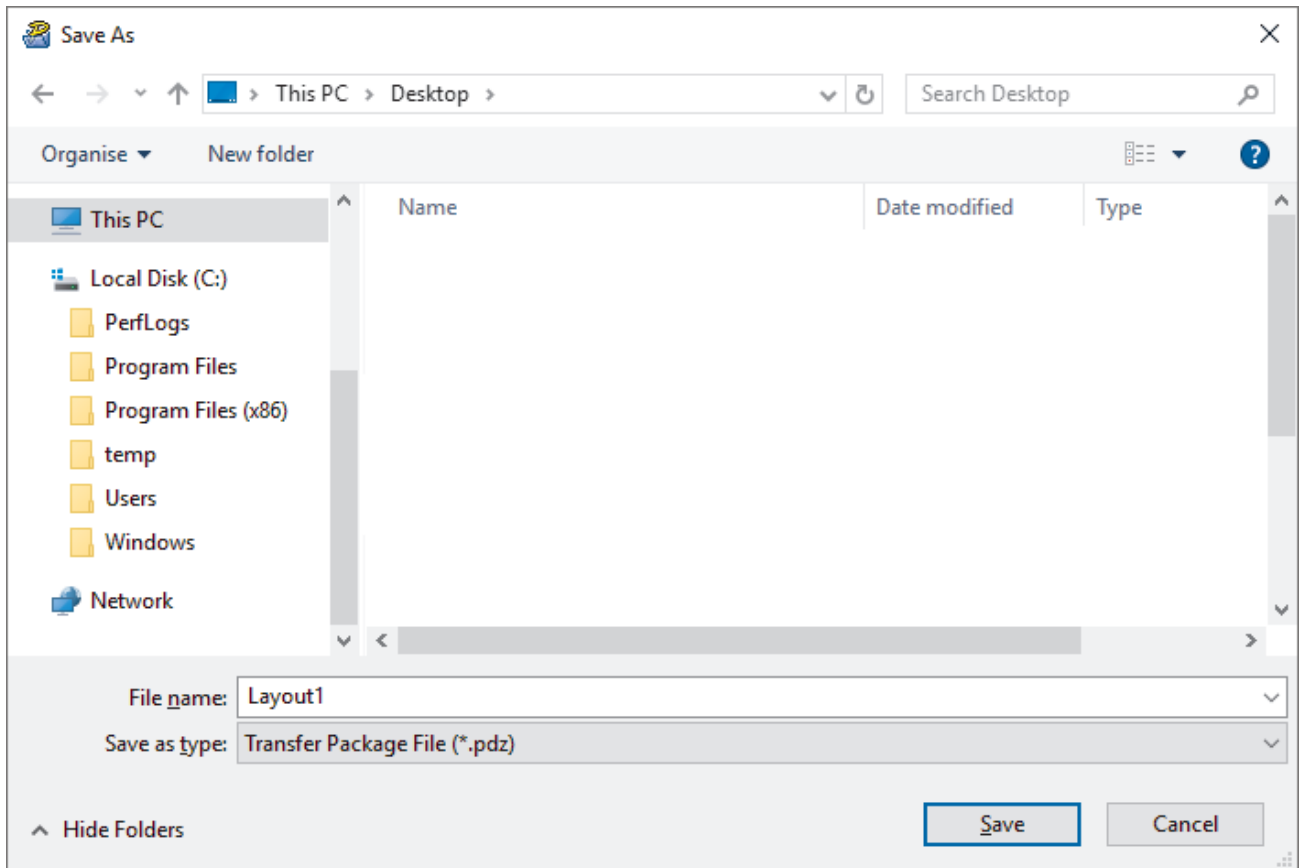

The template is saved as a Transfer Package file (PDZ).

Distribute the Transfer Package File (PDZ) and P-touch Transfer Express to Others



If you already have downloaded P-touch Transfer Express, it is not necessary for the administrator to send the Transfer Express folder. In this case, you can simply move the distributed Transfer Package file to the downloaded folder, and then double-click PtTrExp.exe.

1. Move the Transfer Package file (PDZ) to the downloads folder.

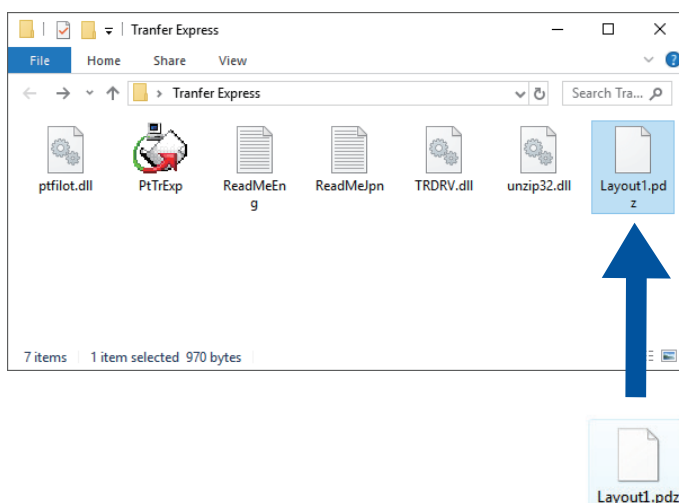

2. Distribute all the files in the downloads folder to others.

User Tasks

Transfer the Transfer Package File (PDZ) to Your Printer



Do not turn off the power when transferring templates.

1. Turn on the printer.
2. Connect the printer to the computer using a USB cable.
3. Double-click the **PtTrExp.exe** file received from the administrator.
4. Do one of the following:
 - To transfer a single Transfer Package file (PDZ) within the folder containing the **PtTrExp.exe** file, click **Transfer**.
 - To transfer multiple Transfer Package files (PDZ) within the folder containing the **PtTrExp.exe** file, do the following:
 - a. Click **Browse**.

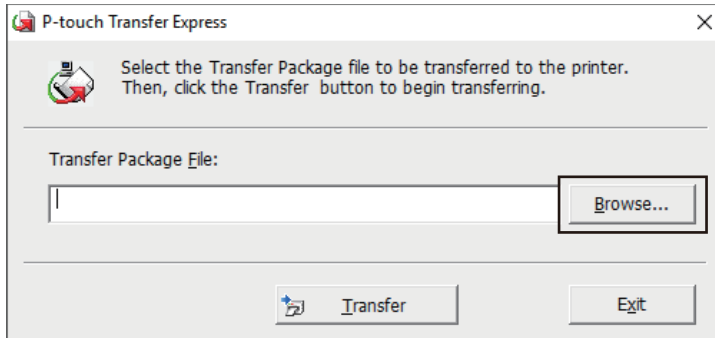

- b. Select the Transfer Package file you want to transfer, and then click **Open**.
 - c. Click **Transfer**.
 - d. Click **Yes**.
5. When completed, click **OK**.



Related Information

- [Transfer Templates to the Printer \(P-touch Transfer Manager\) \(Windows\)](#)

Store or Manage Templates (P-touch Library)

- [Edit Templates Using P-touch Library \(Windows\)](#)
- [Print Templates Using P-touch Library \(Windows\)](#)
- [Search Templates Using P-touch Library \(Windows\)](#)

Edit Templates Using P-touch Library (Windows)

1. Start the P-touch Library.
 - **Windows 10/Windows Server 2016/Windows Server 2019:**
Click **Start > Brother P-touch > P-touch Library**.
 - **Windows 8.1/Windows Server 2012/Windows Server 2012 R2:**
Click the **P-touch Library** icon on the **Apps** screen.
 - **Windows 7**
Click **Start > All Programs > Brother P-touch > P-touch Tools > P-touch Library**.

The main window appears.

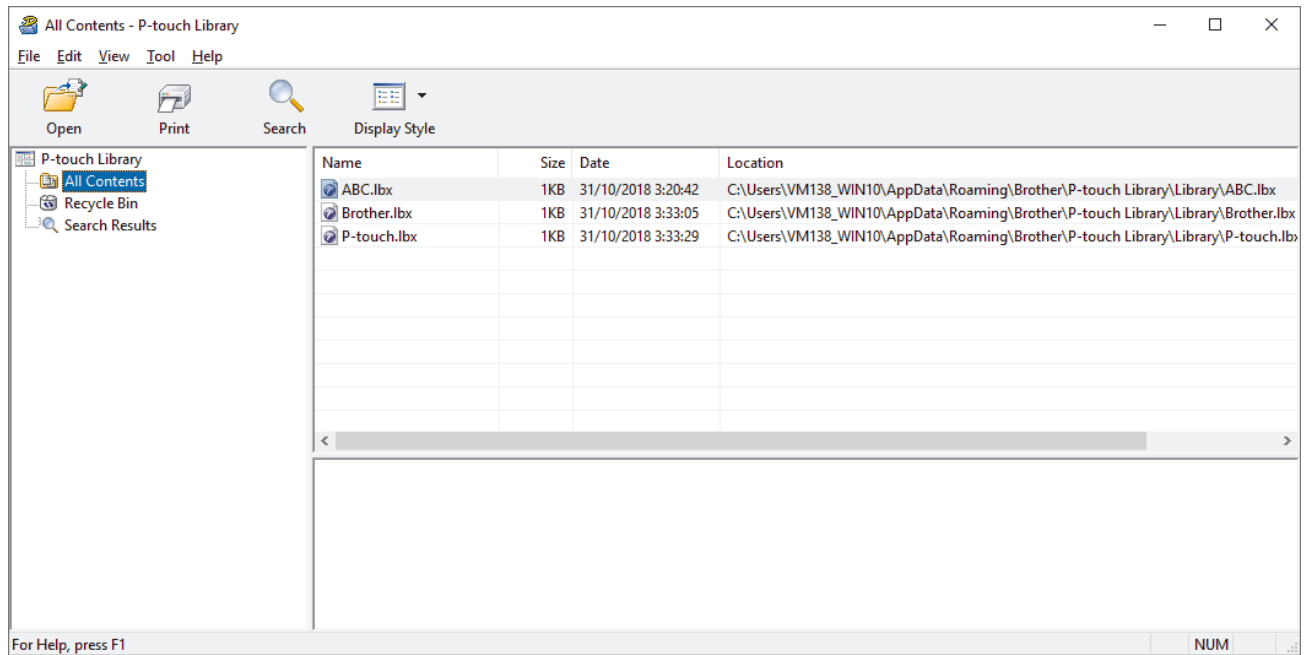

Overview of the Toolbar Icons

Icon	Button name	Function
	Open	Opens the selected template.
	Print	Prints the selected template with the printer.
	Search	Allows you to search for templates registered to P-touch Library.
	Display Style	Changes the file display style.

2. Select the template you want to edit, and then click **Open**.
The program associated with the template launches, allowing you to edit the template.



Related Information

- [Store or Manage Templates \(P-touch Library\)](#)

Print Templates Using P-touch Library (Windows)

1. Start the P-touch Library.

- **Windows 10/Windows Server 2016/Windows Server 2019:**
Click **Start > Brother P-touch > P-touch Library**.
- **Windows 8.1/Windows Server 2012/Windows Server 2012 R2:**
Click the **P-touch Library** icon on the **Apps** screen.
- **Windows 7**
Click **Start > All Programs > Brother P-touch > P-touch Tools > P-touch Library**.

The main window appears.

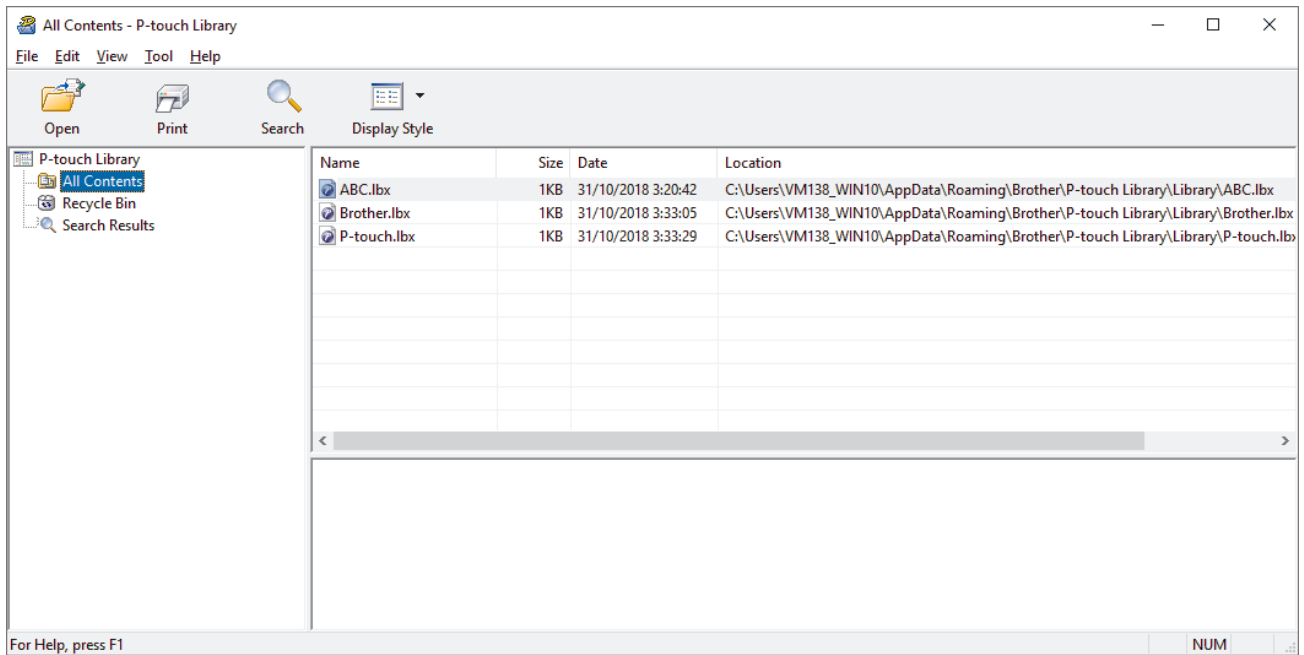

2. Select the template you want to print, and then click **Print**.

The connected printer prints the template.

✓ Related Information

- [Store or Manage Templates \(P-touch Library\)](#)

Search Templates Using P-touch Library (Windows)

1. Start the P-touch Library.

- **Windows 10/Windows Server 2016/Windows Server 2019:**
Click **Start > Brother P-touch > P-touch Library**.
- **Windows 8.1/Windows Server 2012/Windows Server 2012 R2:**
Click the **P-touch Library** icon on the **Apps** screen.
- **Windows 7**
Click **Start > All Programs > Brother P-touch > P-touch Tools > P-touch Library**.

The main window appears.

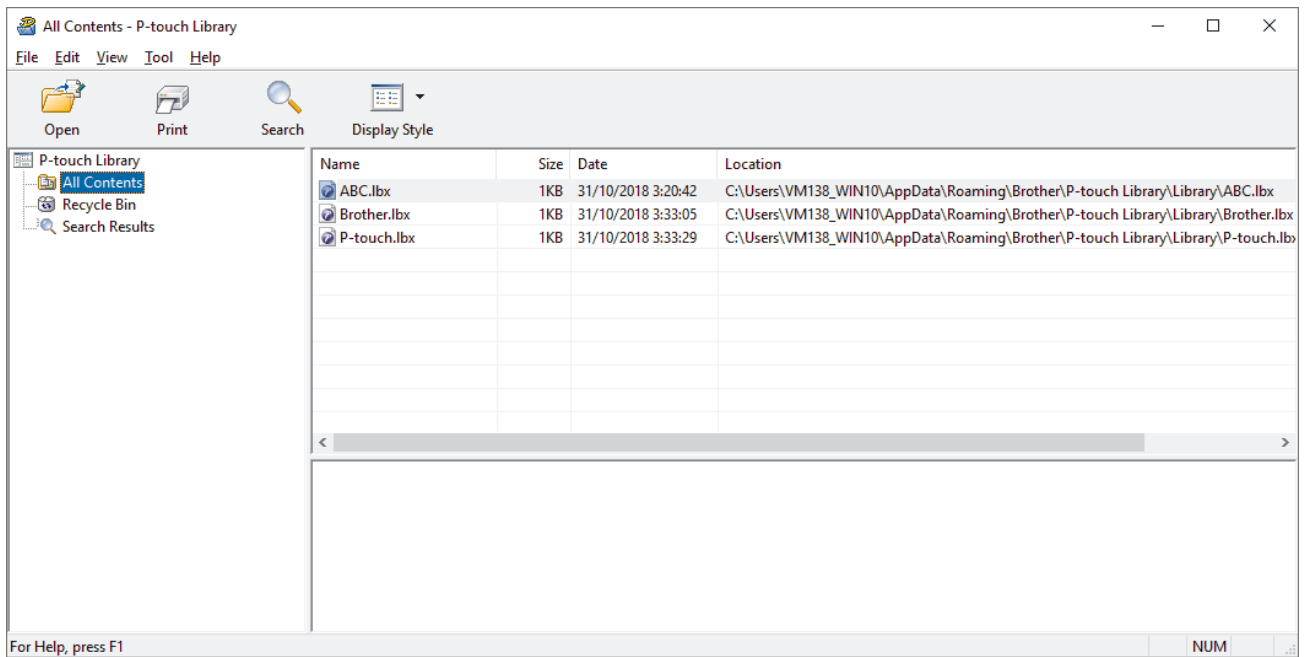

2. Click **Search**.

The **Search** dialog box appears.

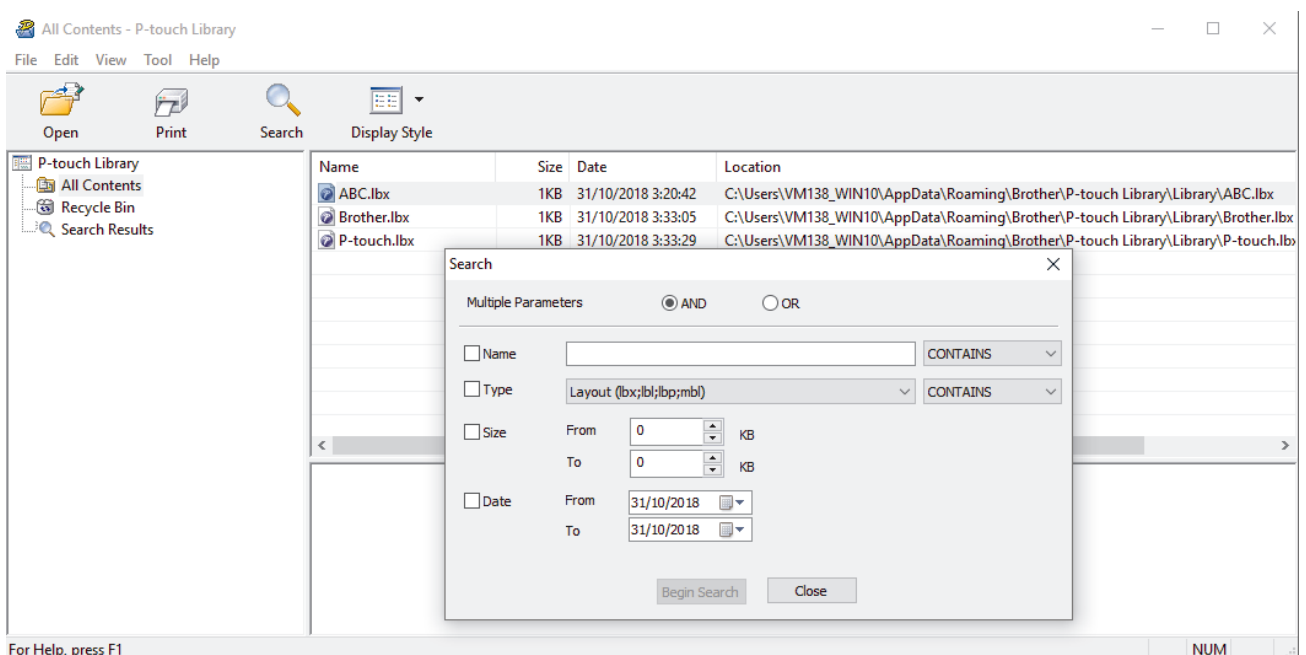

3. Specify the search criteria.

The following search criteria are available:

Settings	Details
Multiple Parameters	Determines how the program searches when multiple criteria are specified. If you select AND , the program searches for files meeting all of the criteria. If you select OR , the program searches for files meeting any of the criteria.
Name	Search for a template by specifying the file name.
Type	Search for a template by specifying the file type.
Size	Search for a template by specifying the file size.
Date	Search for a template by specifying the file date.

- Click **Begin Search**.

The search begins and the search results are displayed.

- Close the **Search** dialog box.

To confirm the search results, click **Search Results** in the folder view.



You can register templates to P-touch Library by dragging and dropping them into the **All Contents** folder or to the folder list.



Related Information

- [Store or Manage Templates \(P-touch Library\)](#)

Network

- [Important Information for Security](#)
- [Wireless Network Settings](#)
- [Network Features](#)
- [Brother Management Tools](#)

Important Information for Security

- The default password to manage this machine's settings is located on the back of the machine and marked "**Pwd**". We recommend immediately changing the default password to protect your machine from unauthorized access.
- When connecting your machine to an outside network such as the Internet, make sure your network environment is protected by a separate firewall or other means in order to prevent information leaks due to inadequate settings or unauthorized access by malicious third parties.
- If there is a signal in the vicinity, wireless LAN allows you to freely make a LAN connection. However, if security settings are not correctly configured, the signal may be intercepted by malicious third-parties, possibly resulting in:
 - Theft of personal or confidential information
 - Improper transmission of information to parties impersonating the specified individuals
 - Dissemination of transcribed communication contents that were intercepted



Related Information

- [Network](#)
-

Wireless Network Settings

Related Models: RJ-3250WB

- [Use the Wireless Network](#)
- [Enable/Disable Wi-Fi](#)

Use the Wireless Network

Related Models: RJ-3250WB

- [Before Configuring Your Machine for a Wireless Network](#)

Before Configuring Your Machine for a Wireless Network

Related Models: RJ-3250WB

Before attempting to configure a wireless network, confirm the following:

- If you are using an enterprise wireless network, you must know the User ID and Password.
- To achieve optimum results with normal everyday document printing, place your machine as close to the wireless LAN access point/router as possible with minimal obstructions. Large objects and walls between the two devices and interference from other electronic devices can affect the data transfer speed of your documents.

Due to these factors, wireless may not be the best method of connection for all types of documents and applications.

- If there is a signal in the vicinity, wireless LAN allows you to freely make a LAN connection. However, if security settings are not correctly configured, the signal may be intercepted by malicious third-parties, possibly resulting in:
 - Theft of personal or confidential information
 - Improper transmission of information to parties impersonating the specified individuals
 - Dissemination of transcribed communication contents that were intercepted



Make sure you know your wireless router/access point's Network Name (SSID) and Network Key (Password). If you cannot find this information, consult the manufacturer of your wireless router/access point, your system administrator, or Internet provider. Brother cannot provide this information.





Related Information

- [Use the Wireless Network](#)

Enable/Disable Wi-Fi

Related Models: RJ-3250WB

1. Press the **Menu** / ▼ (Select) button to select the [WLAN] menu, and then press the  (Feed) / **OK** button.
2. Do one of the following:
 - To enable Wi-Fi, select [On].
 - To disable Wi-Fi, select [Off].
3. Select [On/Off] and then press the  (Feed) / **OK** button.



Related Information

- [Wireless Network Settings](#)

Network Features

- [Synchronize Time with the SNTP Server Using Web Based Management](#)

Synchronize Time with the SNTP Server Using Web Based Management

The Simple Network Time Protocol (SNTP) is used to synchronize the time used by the machine for authentication with the SNTP time server. You can automatically or manually synchronize the machine's time with the Coordinated Universal Time (UTC) provided by the SNTP time server.

- [Configure Date and Time Using Web Based Management](#)
- [Configure the SNTP Protocol Using Web Based Management](#)

Configure Date and Time Using Web Based Management

Configure date and time to synchronize the time used by the machine with the SNTP time server.

This feature is not available in some countries.

1. Start your web browser.
2. Type "https://machine's IP address" in your browser's address bar (where "machine's IP address" is the machine's IP address).

For example:

https://192.168.1.2

3. If required, type the password in the **Login** field, and then click **Login**.



The default password to manage this machine's settings is located on the back of the machine and marked "Pwd".

4. Go to the navigation menu, and then click **Administrator > Date&Time**.



Start from , if the navigation menu is not shown on the left side of the screen.

5. Verify the **Time Zone** settings.



Select the time difference between your location and UTC from the **Time Zone** drop-down list. For example, the time zone for Eastern Time in the USA and Canada is UTC-05:00.

6. Click **Submit**.



Related Information

- [Synchronize Time with the SNTP Server Using Web Based Management](#)

Configure the SNTP Protocol Using Web Based Management

Configure the SNTP protocol to synchronize the time the machine uses for authentication with the time kept by the SNTP time server.

1. Start your web browser.
2. Type "https://machine's IP address" in your browser's address bar (where "machine's IP address" is the machine's IP address).

For example:

https://192.168.1.2

3. If required, type the password in the **Login** field, and then click **Login**.



The default password to manage this machine's settings is located on the back of the machine and marked "Pwd".

4. Go to the navigation menu, and then click **Network > Network > Protocol**.



Start from , if the navigation menu is not shown on the left side of the screen.

5. Select the **SNTP** check box to activate the settings.
6. Click **Submit**.
7. Next to the SNTP check box, click **Advanced Settings**.
8. Configure the settings.

Option	Description
Status	Displays whether the SNTP protocol is enabled or disabled.
Synchronization Status	Confirm the latest synchronization status.
SNTP Server Method	Select AUTO or STATIC . <ul style="list-style-type: none">• AUTO If you have a DHCP server in your network, the SNTP server will obtain the address from that server automatically.• STATIC Type the address you want to use.
Primary SNTP Server Address Secondary SNTP Server Address	Type the server address (up to 64 characters). The secondary SNTP server address is used as a backup to the primary SNTP server address. If the primary server is unavailable, the machine will contact the secondary SNTP server.
Primary SNTP Server Port Secondary SNTP Server Port	Type the port number (1-65535). The secondary SNTP server port is used as a backup to the primary SNTP server port. If the primary port is unavailable, the machine will contact the secondary SNTP port.
Synchronization Interval	Type the number of hours between server synchronization attempts (1-168 hours).

9. Click **Submit**.



Related Information

- [Synchronize Time with the SNTP Server Using Web Based Management](#)

Brother Management Tools

Use one of Brother's management tools to configure your Brother machine's network settings.
Go to your model's **Downloads** page at support.brother.com to download the tools.



Related Information

- [Network](#)
-

Security

- [Before Using Network Security Features](#)
- [Configure Certificates for Device Security](#)
- [Use SSL/TLS](#)
- [Use SNMPv3](#)
- [Use IEEE 802.1x Authentication for a Wired or a Wireless Network](#)

Before Using Network Security Features

Your machine employs some of the latest network security and encryption protocols available today. These network features can be integrated into your overall network security plan to help protect your data and prevent unauthorized access to the machine.



We recommend disabling the FTP server and TFTP protocols. Accessing the machine using these protocols is not secure.



Related Information

- [Security](#)
-

Configure Certificates for Device Security

You must configure a certificate to manage your networked machine securely using SSL/TLS. You must use Web Based Management to configure a certificate.

- [Supported Security Certificate Features](#)
- [Step by Step Guide for Creating and Installing a Certificate](#)
- [Create a Self-signed Certificate](#)
- [Create CSR and Install a Certificate from a Certificate Authority \(CA\)](#)
- [Import and Export the Certificate and Private Key](#)
- [Import and Export a CA Certificate](#)
- [Manage Multiple Certificates](#)

Supported Security Certificate Features

Your machine supports the use of multiple security certificates, which allows secure management, authentication, and communication with the machine. The following security certificate features can be used with the machine:

- SSL/TLS communication
- IEEE 802.1x authentication

Your machine supports the following:

- Self-signed certificate

This print server issues its own certificate. Using this certificate, you can easily use the SSL/TLS communication without creating or installing a different certificate from a CA.

- Certificate from a Certificate Authority (CA)

There are two methods for installing a certificate from a CA. If you already have a certificate from a CA or if you want to use a certificate from an external trusted CA:

- When using a Certificate Signing Request (CSR) from this print server.
- When importing a certificate and a private key.

- Certificate Authority (CA) Certificate

To use a CA certificate that identifies the CA and owns its private key, you must import that CA certificate from the CA before configuring the security features of the Network.



- If you are going to use SSL/TLS communication, we recommend contacting your system administrator first.
- When you reset the print server back to its default factory settings, the certificate and the private key that are installed will be deleted. If you want to keep the same certificate and the private key after resetting the print server, export them before resetting, and then reinstall them.
- When you reset the network settings, the certificate and the private key that are installed will be deleted.



Related Information

- [Configure Certificates for Device Security](#)

Step by Step Guide for Creating and Installing a Certificate

There are two options when choosing a security certificate: use a self-signed certificate or use a certificate from a Certificate Authority (CA).

Option 1

Self-Signed Certificate

1. Create a self-signed certificate using Web Based Management.
2. Install the self-signed certificate on your computer.

Option 2

Certificate from a CA

1. Create a Certificate Signing Request (CSR) using Web Based Management.
2. Install the certificate issued by the CA on your Brother machine using Web Based Management.
3. Install the certificate on your computer.



Related Information

- [Configure Certificates for Device Security](#)
-

Create a Self-signed Certificate

1. Start your web browser.
2. Type "https://machine's IP address" in your browser's address bar (where "machine's IP address" is the machine's IP address).

For example:

https://192.168.1.2



- If you are using a Domain Name System or enable a NetBIOS name, you can type another name, such as "SharedPrinter" instead of the IP address.

- For example:

https://SharedPrinter

If you enable a NetBIOS name, you can also use the node name.

- For example:

https://brnxxxxxxxxxxxx

The NetBIOS name can be found in the Network Configuration Report.

3. If required, type the password in the **Login** field, and then click **Login**.



The default password to manage this machine's settings is located on the back of the machine and marked "Pwd".

4. Go to the navigation menu, and then click **Network > Security > Certificate**.



Start from , if the navigation menu is not shown on the left side of the screen.

5. Click **Create Self-Signed Certificate**.
6. Enter a **Common Name** and a **Valid Date**.
 - The length of the **Common Name** is less than 64 bytes. Enter an identifier, such as an IP address, node name, or domain name to use when accessing this machine through SSL/TLS communication. The node name is displayed by default.
 - A warning will appear if you use the IPPS or HTTPS protocol and enter a different name in the URL than the **Common Name** that was used for the self-signed certificate.
7. Select your setting from the **Public Key Algorithm** drop-down list. The default setting is **RSA(2048bit)**.
8. Select your setting from the **Digest Algorithm** drop-down list. The default setting is **SHA256**.
9. Click **Submit**.



Related Information

- [Configure Certificates for Device Security](#)

Create CSR and Install a Certificate from a Certificate Authority (CA)

If you already have a certificate from an external trusted CA, you can store the certificate and private key on the machine and manage them by importing and exporting. If you do not have a certificate from an external trusted CA, create a Certificate Signing Request (CSR), send it to a CA for authentication, and install the returned certificate on your machine.

- [Create a Certificate Signing Request \(CSR\)](#)
- [Install a Certificate on Your Machine](#)

Create a Certificate Signing Request (CSR)

A Certificate Signing Request (CSR) is a request sent to a Certificate Authority (CA) to authenticate the credentials contained within the certificate.

We recommend installing a Root Certificate from the CA on your computer before creating the CSR.

1. Start your web browser.
2. Type "https://machine's IP address" in your browser's address bar (where "machine's IP address" is the machine's IP address).

For example:

https://192.168.1.2



- If you are using a Domain Name System or enable a NetBIOS name, you can type another name, such as "SharedPrinter" instead of the IP address.

- For example:

https://SharedPrinter

If you enable a NetBIOS name, you can also use the node name.

- For example:

https://brnxxxxxxxxxxxx

The NetBIOS name can be found in the Network Configuration Report.

3. If required, type the password in the **Login** field, and then click **Login**.



The default password to manage this machine's settings is located on the back of the machine and marked "Pwd".

4. Go to the navigation menu, and then click **Network > Security > Certificate**.



Start from ☰, if the navigation menu is not shown on the left side of the screen.

5. Click **Create CSR**.
6. Type a **Common Name** (required) and add other information about your **Organization** (optional).



- Your company details are required so that a CA can confirm your identity and verify it to the outside world.
- The length of the **Common Name** must be less than 64 bytes. Enter an identifier, such as an IP address, node name, or domain name to use when accessing this printer through SSL/TLS communication. The node name is displayed by default. The **Common Name** is required.
- A warning will appear if you type a different name in the URL than the Common Name that was used for the certificate.
- The length of the **Organization**, the **Organization Unit**, the **City/Locality** and the **State/Province** must be less than 64 bytes.
- The **Country/Region** should be a two character ISO 3166 country code.
- If you are configuring an X.509v3 certificate extension, select the **Configure extended partition** check box, and then select **Auto (Register IPv4)** or **Manual**.

7. Select your setting from the **Public Key Algorithm** drop-down list. The default setting is **RSA(2048bit)**.
8. Select your setting from the **Digest Algorithm** drop-down list. The default setting is **SHA256**.
9. Click **Submit**.

The CSR appears on your screen. Save the CSR as a file or copy and paste it into an online CSR form offered by a Certificate Authority.

10. Click **Save**.



- Follow your CA's policy regarding the method to send a CSR to your CA.
 - If you are using the Enterprise root CA of Windows Server 2012/2012 R2/2016/2019, we recommend using the Web Server for the certificate template to securely create the Client Certificate. If you are creating a Client Certificate for an IEEE 802.1x environment with EAP-TLS authentication, we recommend using User for the certificate template.
-



Related Information

- [Create CSR and Install a Certificate from a Certificate Authority \(CA\)](#)
-

Install a Certificate on Your Machine

When you receive a certificate from a CA, follow the steps below to install it into the print server:

Only a certificate issued with your machine's CSR can be installed onto the machine. When you want to create another CSR, make sure that the certificate is installed before creating another CSR. Create another CSR only after installing the certificate on the machine. If you do not, the CSR you create before installing will be invalid.

1. Start your web browser.
2. Type "https://machine's IP address" in your browser's address bar (where "machine's IP address" is the machine's IP address).

For example:

https://192.168.1.2



- If you are using a Domain Name System or enable a NetBIOS name, you can type another name, such as "SharedPrinter" instead of the IP address.

- For example:

https://SharedPrinter

If you enable a NetBIOS name, you can also use the node name.

- For example:

https://brnxxxxxxxxxxxx

The NetBIOS name can be found in the Network Configuration Report.

3. If required, type the password in the **Login** field, and then click **Login**.



The default password to manage this machine's settings is located on the back of the machine and marked "Pwd".

4. Go to the navigation menu, and then click **Network > Security > Certificate**.



Start from ☰, if the navigation menu is not shown on the left side of the screen.

5. Click **Install Certificate**.
6. Browse to the file that contains the certificate issued by the CA, and then click **Submit**.

The certificate has been created successfully and saved in your machine's memory successfully.

To use SSL/TLS communication, the Root Certificate from the CA must be installed on your computer. Contact your network administrator.



Related Information

- [Create CSR and Install a Certificate from a Certificate Authority \(CA\)](#)

Import and Export the Certificate and Private Key

Store the certificate and private key on your machine and manage them by importing and exporting them.

- [Import a Certificate and Private Key](#)
- [Export the Certificate and Private Key](#)

Import a Certificate and Private Key

1. Start your web browser.
2. Type "https://machine's IP address" in your browser's address bar (where "machine's IP address" is the machine's IP address).

For example:

https://192.168.1.2



- If you are using a Domain Name System or enable a NetBIOS name, you can type another name, such as "SharedPrinter" instead of the IP address.

- For example:

https://SharedPrinter

If you enable a NetBIOS name, you can also use the node name.

- For example:

https://brnxxxxxxxxxxxx

The NetBIOS name can be found in the Network Configuration Report.

3. If required, type the password in the **Login** field, and then click **Login**.



The default password to manage this machine's settings is located on the back of the machine and marked "Pwd".

4. Go to the navigation menu, and then click **Network > Security > Certificate**.



Start from , if the navigation menu is not shown on the left side of the screen.

5. Click **Import Certificate and Private Key**.
6. Browse to the file you want to import.
7. Type the password if the file is encrypted, and then click **Submit**.

The certificate and private key are imported to your machine.



Related Information

- [Import and Export the Certificate and Private Key](#)

Export the Certificate and Private Key

1. Start your web browser.
2. Type "https://machine's IP address" in your browser's address bar (where "machine's IP address" is the machine's IP address).

For example:

https://192.168.1.2



- If you are using a Domain Name System or enable a NetBIOS name, you can type another name, such as "SharedPrinter" instead of the IP address.

- For example:

https://SharedPrinter

If you enable a NetBIOS name, you can also use the node name.

- For example:

https://brnxxxxxxxxxxxx

The NetBIOS name can be found in the Network Configuration Report.

3. If required, type the password in the **Login** field, and then click **Login**.



The default password to manage this machine's settings is located on the back of the machine and marked "Pwd".

4. Go to the navigation menu, and then click **Network > Security > Certificate**.



Start from , if the navigation menu is not shown on the left side of the screen.

5. Click **Export** shown with **Certificate List**.
6. Enter the password if you want to encrypt the file.
If a blank password is used, the output is not encrypted.
7. Enter the password again for confirmation, and then click **Submit**.
8. Click **Save**.

The certificate and private key are exported to your computer.

You can also import the certificate to your computer.



Related Information

- [Import and Export the Certificate and Private Key](#)

Import and Export a CA Certificate

You can import, export, and store CA certificates on your Brother machine.

- [Import a CA Certificate](#)
- [Export a CA Certificate](#)

Import a CA Certificate

1. Start your web browser.
2. Type "https://machine's IP address" in your browser's address bar (where "machine's IP address" is the machine's IP address).

For example:

https://192.168.1.2



- If you are using a Domain Name System or enable a NetBIOS name, you can type another name, such as "SharedPrinter" instead of the IP address.

- For example:

https://SharedPrinter

If you enable a NetBIOS name, you can also use the node name.

- For example:

https://brnxxxxxxxxxxxxx

The NetBIOS name can be found in the Network Configuration Report.

3. If required, type the password in the **Login** field, and then click **Login**.



The default password to manage this machine's settings is located on the back of the machine and marked "Pwd".

4. Go to the navigation menu, and then click **Network > Security > CA Certificate**.



Start from ☰, if the navigation menu is not shown on the left side of the screen.

5. Click **Import CA Certificate**.
6. Browse to the file you want to import.
7. Click **Submit**.



Related Information

- [Import and Export a CA Certificate](#)

Export a CA Certificate

1. Start your web browser.
2. Type "https://machine's IP address" in your browser's address bar (where "machine's IP address" is the machine's IP address).

For example:

https://192.168.1.2



- If you are using a Domain Name System or enable a NetBIOS name, you can type another name, such as "SharedPrinter" instead of the IP address.

- For example:

https://SharedPrinter

If you enable a NetBIOS name, you can also use the node name.

- For example:

https://brnxxxxxxxxxxxx

The NetBIOS name can be found in the Network Configuration Report.

3. If required, type the password in the **Login** field, and then click **Login**.



The default password to manage this machine's settings is located on the back of the machine and marked "Pwd".

4. Go to the navigation menu, and then click **Network > Security > CA Certificate**.



Start from ☰, if the navigation menu is not shown on the left side of the screen.

5. Select the certificate you want to export and click **Export**.
6. Click **Submit**.
7. Click ▼ next to **Save**, and then specify the location where you want to save the file.



Related Information

- [Import and Export a CA Certificate](#)

Manage Multiple Certificates

The multiple certificate feature allows you to use Web Based Management to manage each certificate installed on your machine. In Web Based Management, navigate to the **Certificate** or **CA Certificate** screen to view certificate content, delete, or export your certificates.

	Maximum Number of Certificates Stored on Brother Machine
Self-signed Certificate or Certificate Issued by a CA	5
CA Certificate	6

We recommend storing fewer certificates than allowed, reserving an empty spot in case of certificate expiration. When a certificate expires, import a new certificate into the reserved spot, and then delete the expired certificate. This ensures that you avoid configuration failure.



When you use HTTPS/IPPS, or IEEE 802.1x, you must select which certificate you are using.



Related Information

- [Configure Certificates for Device Security](#)

Use SSL/TLS

- [Introduction to SSL/TLS](#)
- [Manage Your Network Machine Securely Using SSL/TLS](#)
- [Print Documents Securely Using SSL/TLS](#)

Introduction to SSL/TLS

Secure Socket Layer (SSL) or Transport Layer Security (TLS) is an effective method of protecting data sent over a local or wide area network (LAN or WAN). It works by encrypting data, such as a print job, sent over a network, so anyone trying to capture it will not be able to read it.

SSL/TLS can be configured on both wired and wireless networks and will work with other forms of security such as WPA keys and firewalls.



Related Information

- [Use SSL/TLS](#)
 - [Brief History of SSL/TLS](#)
 - [Benefits of Using SSL/TLS](#)

Brief History of SSL/TLS

SSL/TLS was originally created to secure web traffic information, particularly data sent between web browsers and servers. For example, when you use Internet Explorer for Internet Banking and you see https:// and the little padlock icon in the web browser, you are using SSL. SSL grew to work with additional applications, such as Telnet, printer, and FTP software, in order to become a universal solution for online security. Its original design intentions are still being used today by many online retailers and banks to secure sensitive data, such as credit card numbers, customer records, etc.

SSL/TLS uses extremely high levels of encryption and is trusted by banks all over the world.



Related Information

- [Introduction to SSL/TLS](#)
-

Benefits of Using SSL/TLS

The primary benefit of using SSL/TLS is to guarantee secure printing over an IP network by restricting unauthorized users from reading data sent to the machine. SSL's key selling point is that it can be used to print confidential data securely. For example, an HR department in a large company may be printing wage slips on a regular basis. Without encryption, the data contained on these wages slips can be read by other network users. However, with SSL/TLS, anyone trying to capture the data will see a confusing page of code and not the actual wage slip.



Related Information

- [Introduction to SSL/TLS](#)
-

Manage Your Network Machine Securely Using SSL/TLS

- [Configure a Certificate for SSL/TLS and Available Protocols](#)
- [Access Web Based Management Using SSL/TLS](#)
- [Install the Self-signed Certificate for Windows users with Administrator Rights](#)

Configure a Certificate for SSL/TLS and Available Protocols

Configure a certificate on your machine using Web Based Management before you use SSL/TLS communication.

1. Start your web browser.
2. Type "https://machine's IP address" in your browser's address bar (where "machine's IP address" is the machine's IP address).

For example:

https://192.168.1.2



- If you are using a Domain Name System or enable a NetBIOS name, you can type another name, such as "SharedPrinter" instead of the IP address.

- For example:

https://SharedPrinter

If you enable a NetBIOS name, you can also use the node name.

- For example:

https://brnxxxxxxxxxxxx

The NetBIOS name can be found in the Network Configuration Report.

3. If required, type the password in the **Login** field, and then click **Login**.



The default password to manage this machine's settings is located on the back of the machine and marked "Pwd".

4. Go to the navigation menu, and then click **Network > Network > Protocol**.



Start from ☰, if the navigation menu is not shown on the left side of the screen.

5. Click **HTTP Server Settings**.
6. Select the certificate you want to configure from the **Select the Certificate** drop-down list.
7. Click **Submit**.
8. Click **Yes** to restart your print server.



Related Information

- [Manage Your Network Machine Securely Using SSL/TLS](#)

Access Web Based Management Using SSL/TLS

To manage your network machine securely, use Web Based Management with the HTTPS protocol.



- To use HTTPS protocol, HTTPS must be enabled on your machine. The HTTPS protocol is enabled by default.
- You can change the HTTPS protocol settings using the Web Based Management screen.

1. Start your web browser.
2. Type "https://machine's IP address" in your browser's address bar (where "machine's IP address" is the machine's IP address).
3. If required, type the password in the **Login** field, and then click **Login**.



The default password to manage this machine's settings is located on the back of the machine and marked "Pwd".

4. You can now access the machine using HTTPS.







Related Information

- [Manage Your Network Machine Securely Using SSL/TLS](#)

Install the Self-signed Certificate for Windows users with Administrator Rights

The following steps are for Microsoft Internet Explorer. If you use another web browser, consult the documentation for your web browser to get help with installing certificates.

1. Do one of the following:
 - Windows 10, Windows Server 2016, and Windows Server 2019
Click  > **Windows Accessories**.
 - Windows 8.1
Right-click the  (**Internet Explorer**) icon on the taskbar.
 - Windows Server 2012 and Windows Server 2012 R2
Click , and then right-click the  (**Internet Explorer**) icon that appears on the taskbar.
 - Windows 7
Click  (**Start**) > **All Programs**.
2. Right-click **Internet Explorer**, and then click **Run as administrator**.



If the **More** option appears, click **More**.

If the **User Account Control** screen appears, click **Yes**.

3. Type "https://machine's IP address" in your browser's address bar to access your machine (where "machine's IP address" is the machine's IP address or the node name that you assigned for the certificate).
4. Click **More information**.
5. Click **Go on to the webpage (not recommended)**.
6. Click **Certificate error**, and then click **View certificates**.

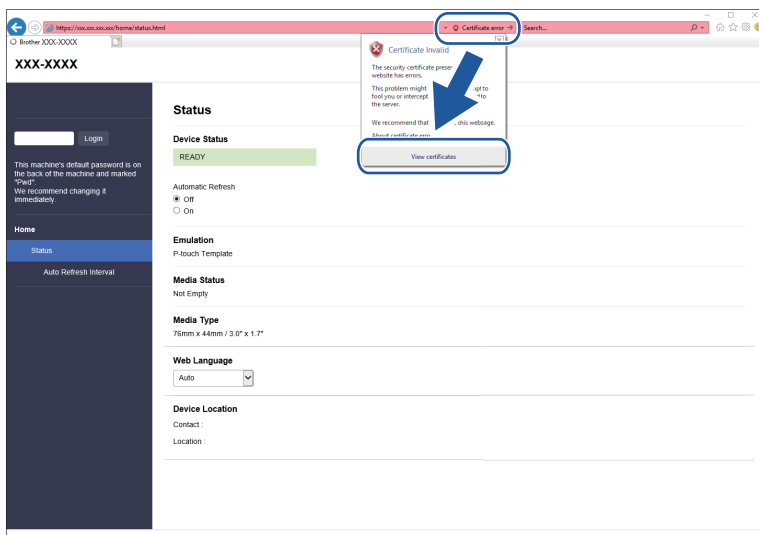

7. Click **Install Certificate...**
8. When the **Certificate Import Wizard** appears, click **Next**.
9. Select **Place all certificates in the following store**, and then click **Browse...**
10. Select **Trusted Root Certification Authorities**, and then click **OK**.
11. Click **Next**.
12. Click **Finish**.

13. Click **Yes**, if the fingerprint (thumbprint) is correct.

14. Click **OK**.



Related Information

- [Manage Your Network Machine Securely Using SSL/TLS](#)
-

Print Documents Securely Using SSL/TLS

- [Print Documents Using SSL/TLS](#)

Print Documents Using SSL/TLS

To print documents securely with IPP protocol, use the IPPS protocol.

1. Start your web browser.
2. Type "https://machine's IP address" in your browser's address bar (where "machine's IP address" is the machine's IP address).

For example:

https://192.168.1.2



- If you are using a Domain Name System or enable a NetBIOS name, you can type another name, such as "SharedPrinter" instead of the IP address.

- For example:

https://SharedPrinter

If you enable a NetBIOS name, you can also use the node name.

- For example:

https://brnxxxxxxxxxxxx

The NetBIOS name can be found in the Network Configuration Report.

3. If required, type the password in the **Login** field, and then click **Login**.



The default password to manage this machine's settings is located on the back of the machine and marked "Pwd".

4. Go to the navigation menu, and then click **Network > Network > Protocol**.



Start from ☰, if the navigation menu is not shown on the left side of the screen.

5. Make sure the **IPP** check box is selected.



If the **IPP** check box is not selected, select the **IPP** check box, and then click **Submit**.

Restart your machine to activate the configuration.

After the machine restarts, return to the machine's web page, type the password, go to the navigation menu, and then click **Network > Network > Protocol**.

6. Click **HTTP Server Settings**.
7. Select the **HTTPS(Port 443)** check box in the **IPP**, and then click **Submit**.
8. Restart your machine to activate the configuration.

Communication using IPPS cannot prevent unauthorized access to the print server.



Related Information

- [Print Documents Securely Using SSL/TLS](#)

Use SNMPv3

- [Manage Your Network Machine Securely Using SNMPv3](#)

Manage Your Network Machine Securely Using SNMPv3

The Simple Network Management Protocol version 3 (SNMPv3) provides user authentication and data encryption to manage network devices securely.

1. Start your web browser.
2. Type "https://Common Name" in your browser's address bar (where "Common Name" is the Common Name that you assigned to the certificate; this could be your IP address, node name, or domain name).
3. If required, type the password in the **Login** field, and then click **Login**.





The default password to manage this machine's settings is located on the back of the machine and marked "Pwd".

4. Go to the navigation menu, and then click **Network > Network > Protocol**.



Start from , if the navigation menu is not shown on the left side of the screen.

5. Make sure the **SNMP** setting is enabled, and then click **Advanced Settings**.
6. Configure the SNMP settings.

Option	Description
SNMP v1/v2c read-write access	The print server uses version 1 and version 2c of the SNMP protocol. You can use all of your machine's applications in this mode. However, it is not secure since it will not authenticate the user, and data will not be encrypted.
SNMPv3 read-write access and v1/v2c read-only access	<p>The print server uses the read-write access of version 3 and the read-only access of version 1 and version 2c of the SNMP protocol.</p> <p> When you use the SNMPv3 read-write access and v1/v2c read-only access mode, some of your machine's applications that access the print server do not work correctly since they authorize the read-only access of version 1 and version 2c. If you want to use all applications, we recommend using the SNMP v1/v2c read-write access mode.</p>
SNMPv3 read-write access	<p>The print server uses version 3 of the SNMP protocol. If you want to manage the print server securely, use this mode.</p> <p> When you use the SNMPv3 read-write access mode, note the following:</p> <ul style="list-style-type: none">• Except for BRAdmin Professional, all applications that use SNMPv1/v2c will be restricted. To allow the use of SNMPv1/v2c applications, use the SNMPv3 read-write access and v1/v2c read-only access or SNMP v1/v2c read-write access mode.

7. Click **Submit**.



Related Information

- [Use SNMPv3](#)

Use IEEE 802.1x Authentication for a Wired or a Wireless Network

- [What Is IEEE 802.1x Authentication?](#)
- [Configure IEEE 802.1x Authentication for a Wired or Wireless Network Using Web Based Management \(Web Browser\)](#)
- [IEEE 802.1x Authentication Methods](#)

What Is IEEE 802.1x Authentication?

IEEE 802.1x is an IEEE standard for wired and wireless networks that limits access from unauthorized network devices. Your Brother machine (supplicant) sends an authentication request to a RADIUS server (Authentication server) through your access point or hub. After your request has been verified by the RADIUS server, your machine can access the network.



Related Information

- [Use IEEE 802.1x Authentication for a Wired or a Wireless Network](#)
-

Configure IEEE 802.1x Authentication for a Wired or Wireless Network Using Web Based Management (Web Browser)

- If you configure your machine using EAP-TLS authentication, you must install the client certificate issued by a CA before you start configuration. Contact your network administrator about the client certificate. If you have installed more than one certificate, we recommend writing down the certificate name you want to use.
- Before you verify the server certificate, you must import the CA certificate issued by the CA that signed the server certificate. Contact your network administrator or your Internet Service Provider (ISP) to confirm whether a CA certificate import is necessary.

1. Start your web browser.
2. Type "https://machine's IP address" in your browser's address bar (where "machine's IP address" is the machine's IP address).

For example:

https://192.168.1.2



- If you are using a Domain Name System or enable a NetBIOS name, you can type another name, such as "SharedPrinter" instead of the IP address.

- For example:

https://SharedPrinter

If you enable a NetBIOS name, you can also use the node name.

- For example:

https://brnxxxxxxxxxxxx

The NetBIOS name can be found in the Network Configuration Report.

3. If required, type the password in the **Login** field, and then click **Login**.



The default password to manage this machine's settings is located on the back of the machine and marked "**Pwd**".

4. Go to the navigation menu, and then click **Network**.



Start from , if the navigation menu is not shown on the left side of the screen.

5. Do one of the following:
 - For the wired network
Click **Wired** > **Wired 802.1x Authentication**.
 - For the wireless network
Click **Wireless** > **Wireless (Enterprise)**.
6. Configure the IEEE 802.1x authentication settings.



- To enable IEEE 802.1x authentication for wired networks, select **Enabled** for **Wired 802.1x status** on the **Wired 802.1x Authentication** page.
- If you are using **EAP-TLS** authentication, you must select the client certificate installed (shown with certificate name) for verification from the **Client Certificate** drop-down list.
- If you select **EAP-FAST**, **PEAP**, **EAP-TTLS**, or **EAP-TLS** authentication, select the verification method from the **Server Certificate Verification** drop-down list. Verify the server certificate using the CA certificate, imported to the machine in advance, issued by the CA that signed the server certificate.

Select one of the following verification methods from the **Server Certificate Verification** drop-down list:

Option	Description
No Verification	The server certificate can always be trusted. The verification is not performed.
CA Cert.	The verification method to check the CA reliability of the server certificate, using the CA certificate issued by the CA that signed the server certificate.
CA Cert. + ServerID	The verification method to check the common name ¹ value of the server certificate, in addition to the CA reliability of the server certificate.

7. When finished with configuration, click **Submit**.

For wired networks: After configuring, connect your machine to the IEEE 802.1x supported network. After a few minutes, print the Network Configuration Report to check the <**Wired IEEE 802.1x**> status.

Option	Description
Success	The wired IEEE 802.1x function is enabled and the authentication was successful.
Failed	The wired IEEE 802.1x function is enabled; however, the authentication failed.
Off	The wired IEEE 802.1x function is not available.



Related Information

- [Use IEEE 802.1x Authentication for a Wired or a Wireless Network](#)

Related Topics:

- [Configure Certificates for Device Security](#)

¹ The common name verification compares the common name of the server certificate to the character string configured for the **Server ID**. Before you use this method, contact your system administrator about the server certificate's common name and then configure **Server ID**.

IEEE 802.1x Authentication Methods

EAP-FAST

Extensible Authentication Protocol-Flexible Authentication via Secured Tunneling (EAP-FAST) has been developed by Cisco Systems, Inc., which uses a user ID and password for authentication, and symmetric key algorithms to achieve a tunneled authentication process.

The Brother machine supports the following inner authentication methods:

- EAP-FAST/NONE
- EAP-FAST/MS-CHAPv2
- EAP-FAST/GTC

EAP-MD5 (Wired network)

Extensible Authentication Protocol-Message Digest Algorithm 5 (EAP-MD5) uses a user ID and password for challenge-response authentication.

PEAP

Protected Extensible Authentication Protocol (PEAP) is a version of EAP method developed by Cisco Systems, Inc., Microsoft Corporation and RSA Security. PEAP creates an encrypted Secure Sockets Layer (SSL)/Transport Layer Security (TLS) tunnel between a client and an authentication server, for sending a user ID and password. PEAP provides mutual authentication between the server and the client.

The Brother machine supports the following inner authentications:

- PEAP/MS-CHAPv2
- PEAP/GTC

EAP-TTLS

Extensible Authentication Protocol-Tunneled Transport Layer Security (EAP-TTLS) has been developed by Funk Software and Certicom. EAP-TTLS creates a similar encrypted SSL tunnel to PEAP, between a client and an authentication server, for sending a user ID and password. EAP-TTLS provides mutual authentication between the server and the client.

The Brother machine supports the following inner authentications:

- EAP-TTLS/CHAP
- EAP-TTLS/MS-CHAP
- EAP-TTLS/MS-CHAPv2
- EAP-TTLS/PAP

EAP-TLS

Extensible Authentication Protocol-Transport Layer Security (EAP-TLS) requires digital certificate authentication both at a client and an authentication server.



Related Information

- [Use IEEE 802.1x Authentication for a Wired or a Wireless Network](#)

Update

- [Update P-touch Editor](#)
- [Update the Firmware](#)

Update P-touch Editor

Before updating P-touch Editor, install the printer driver.

1. Start the P-touch Update Software.
 - **Windows 10/Windows Server 2016/Windows Server 2019:**
Click **Start > Brother P-touch > P-touch Update Software**, or double-click the **P-touch Update Software** icon on the desktop.
 - **Windows 8.1/Windows Server 2012/Windows Server 2012 R2:**
Click the **P-touch Update Software** icon on the **Apps** screen, or double-click the **P-touch Update Software** icon on the desktop.
 - **Windows 7**
Click **Start > All Programs > Brother P-touch > P-touch Update Software**, or double-click the **P-touch Update Software** icon on the desktop.
2. Click the **Computer software update** icon.

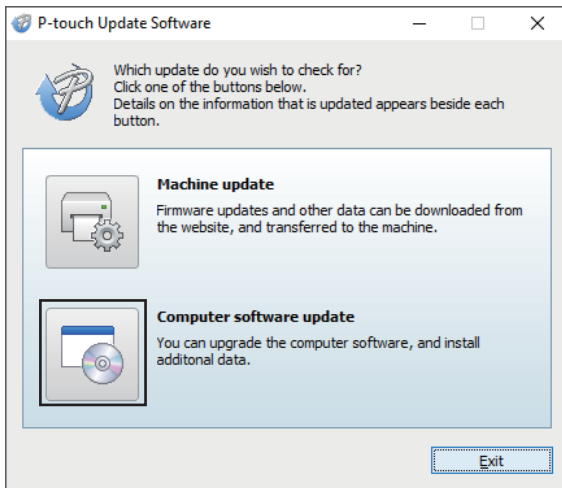

3. Select the **Printer** and **Language** options using the drop-down lists.
4. Select the P-touch Editor check box and click **Install**.

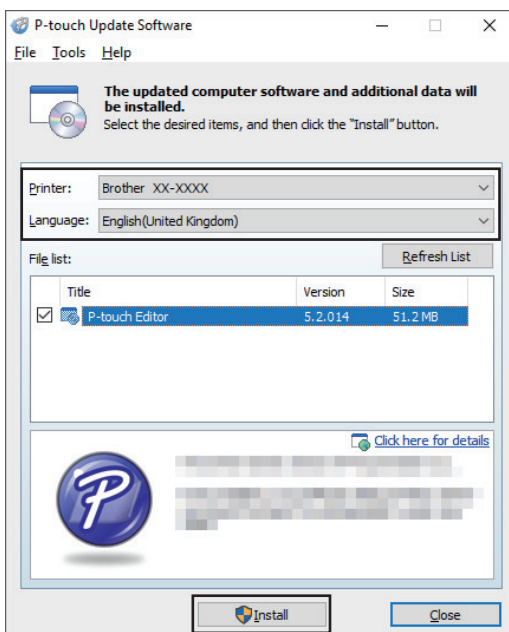

When finished, a confirmation dialog appears.



Related Information

- [Update](#)

Update the Firmware

- Before updating the firmware, you must first install the printer driver.
- Do not turn off the power when transferring data or updating firmware.
- If any other application is running, exit the application.

1. Turn on the printer and connect the USB cable.
2. Start the P-touch Update Software.
 - **Windows 10/Windows Server 2016/Windows Server 2019:**
Click **Start > Brother P-touch > P-touch Update Software**, or double-click the **P-touch Update Software** icon on the desktop.
 - **Windows 8.1/Windows Server 2012/Windows Server 2012 R2:**
Click the **P-touch Update Software** icon on the **Apps** screen, or double-click the **P-touch Update Software** icon on the desktop.
 - **Windows 7**
Click **Start > All Programs > Brother P-touch > P-touch Update Software**, or double-click the **P-touch Update Software** icon on the desktop.
3. Click the **Machine update** icon.

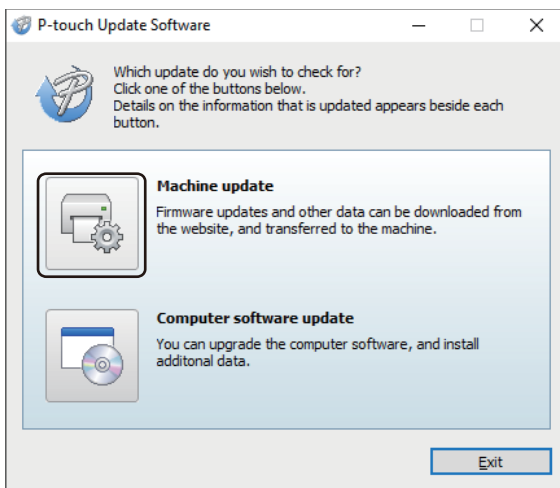

4. Select the **Printer** option, make sure the machine is connected correctly, and then click **OK**.

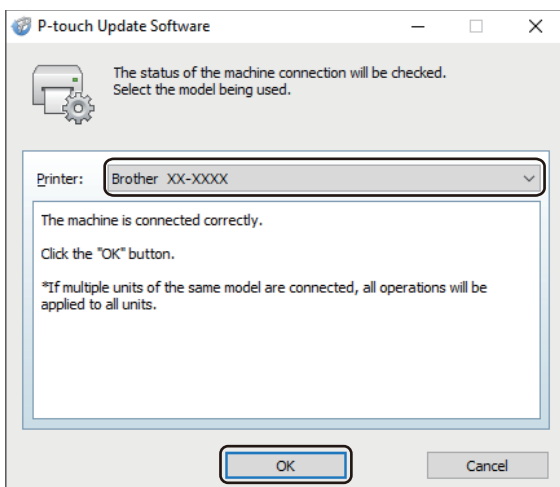

5. Select the **Language** options using the drop-down lists.
6. Select the check box next to the firmware you want to update and then click **Transfer**.

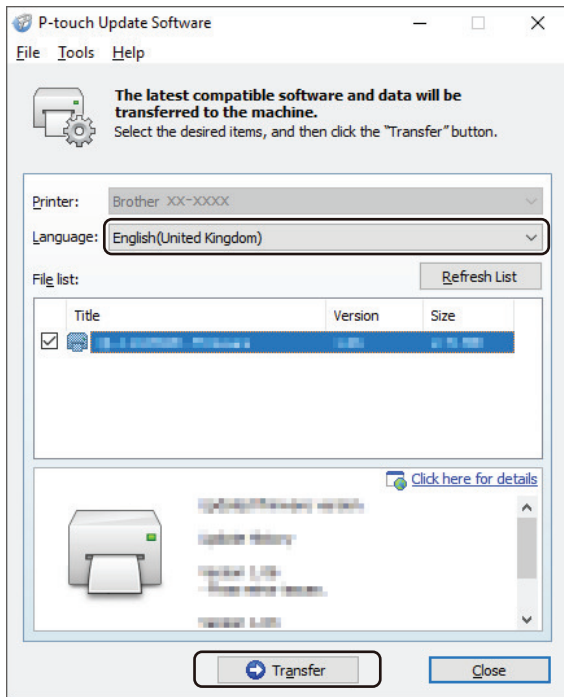

NOTE

Do not turn off the printer or disconnect the cable during the update process and data transfer.

7. Check the content to be updated, and then click **Start** to begin the update.
The firmware update begins.

✓ Related Information

- [Update](#)

Printer Settings

- [Change Printer Settings Using the Printer Setting Tool \(Windows\)](#)
- [Apply Setting Changes to Multiple Printers \(Windows\)](#)
- [Change Printer Settings Using Web Based Management](#)
- [Confirm Printer Settings](#)
- [Change Printer Settings Using the Printer](#)

Change Printer Settings Using the Printer Setting Tool (Windows)

- Make sure the printer driver has been installed correctly and you can print.
- Connect the printer to a computer with a USB cable.



- The Printer Setting Tool is installed in addition to the printer driver and other software when using the installer.

1. Connect the printer you want to configure to the computer.
2. Start the Printer Setting Tool.
 - **Windows 10/Windows Server 2016/Windows Server 2019:**
Click **Start > Brother > Printer Setting Tool**.
 - **Windows 8.1/Windows Server 2012/Windows Server 2012 R2:**
Click the **Printer Setting Tool** icon on the **Apps** screen.
 - **Windows 7**
Click **Start > All Programs > Brother > Label & Mobile Printer > Printer Setting Tool**.

The main window appears.

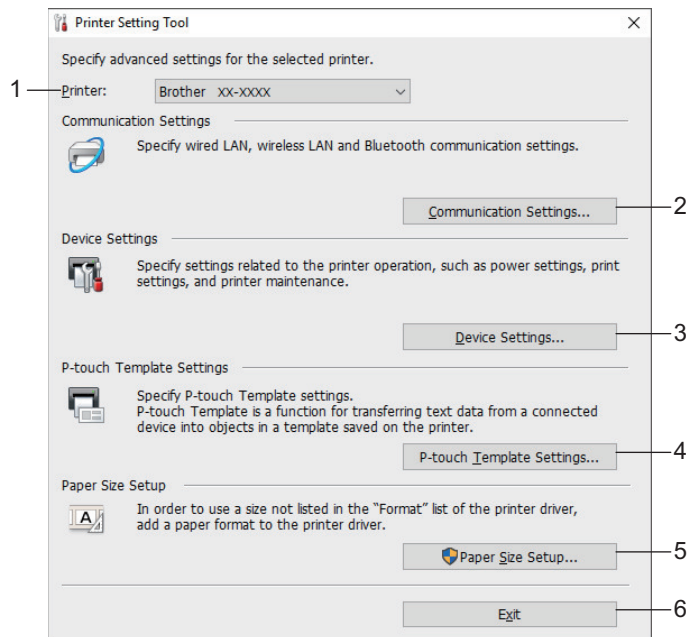

- 1. Printer**
Lists the connected printers.
- 2. Communication Settings**
(RJ-3250WB) Specifies wired LAN, wireless LAN (Wi-Fi), and Bluetooth communication settings.
(RJ-3230B) Specifies wired LAN and Bluetooth communication settings.
- 3. Device Settings**
Specifies device settings.
- 4. P-touch Template Settings**
Specifies P-touch Template settings.
For more information, see the *P-touch Template Manual/Command Reference* (English only). You can download the latest version from the Brother support website at support.brother.com/manuals.
- 5. Paper Size Setup**
Add media information and settings to the printer driver to use sizes not listed in the **Paper Size** list of the printer driver.

NOTE

To open **Paper Size Setup**, you must be logged on with administrator rights.

6. Exit

Closes the window.

3. Make sure the printer you want to configure appears next to **Printer**.
If a different printer appears, select the printer you want from the drop-down list.
4. Select the settings you want to change, and then specify or change the settings in the dialog box.
5. Click **Apply** to apply the settings to the printer.
6. Click **Exit** in the main window to finish specifying settings.



Use the Printer Setting Tool to configure the printer only when the printer is idle. The printer may malfunction if you try to configure it while it is processing or printing a print job.



Related Information

- [Printer Settings](#)
 - [Communication Settings of the Printer Setting Tool \(Windows\)](#)
 - [Device Settings of the Printer Setting Tool \(Windows\)](#)
 - [P-touch Template Settings of the Printer Setting Tool \(Windows\)](#)
 - [The Paper Size Setup Feature of the Printer Setting Tool \(Windows\)](#)
-

Communication Settings of the Printer Setting Tool (Windows)

Use Communication Settings in the Printer Setting Tool to specify or change the printer communication information, when connecting the printer and computer with a USB cable or via a Bluetooth connection. Not only can you change the communication settings for one printer, but you can also apply the same settings to multiple printers.

>> Settings Dialog Box

>> Menu Bar

>> General Tab

>> Wired LAN/Wireless LAN Tabs (RJ-3250WB)Wired LAN Tab(RJ-3230B)

>> Wireless Direct Tab (RJ-3250WB)

>> Bluetooth Tab

Settings Dialog Box

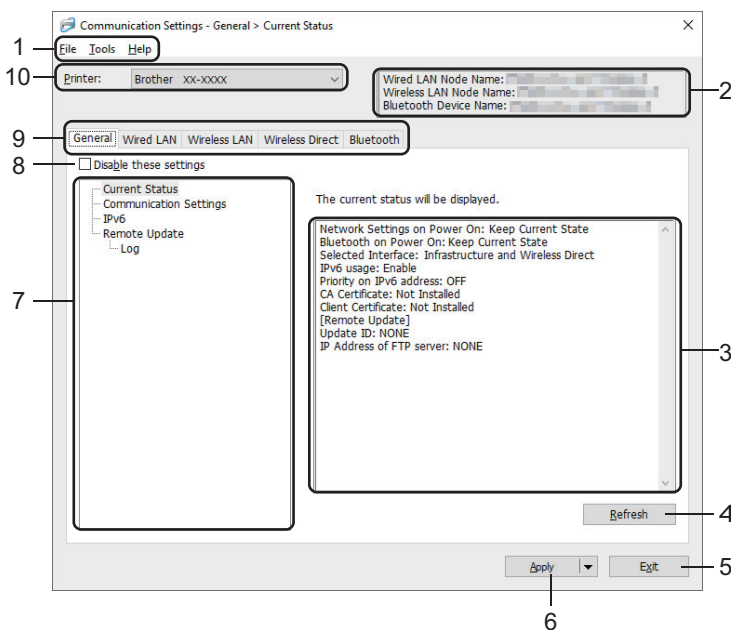

1. Menu Bar

Provides access to various commands grouped under each menu title (the **File**, **Tools**, and **Help** menus) according to their functions.

2. Device Name

Displays the device name.

3. Settings Display/Change Area

Displays the current settings for the selected item.

4. Refresh

Updates the displayed settings with the most recent information.

5. Exit

Exits the **Communication Settings** window, and returns to the main window of the Printer Setting Tool.



Settings are not applied to printers if **Exit** is clicked without clicking the **Apply** button after changing the settings.

6. Apply

Applies the settings to the printer. To save the specified settings in a command file, select the **Save in Command File** command from the drop-down list. The saved command file can be used with the mass storage mode to apply the settings to a printer.





Clicking **Apply** applies all settings in all tabs to the printer. If the **Disable these settings** check box is selected, the settings are not applied.

7. Items

When the **Current Status** menu is selected, the current settings appear in the settings display/change area. Select the item for the settings you want to change.

8. Disable these settings

When this check box is selected,  appears in the tab, and the settings can no longer be specified or changed. Settings in a tab where  appears are not applied to the printer even if **Apply** is clicked. In addition, the settings in the tab are not saved or exported when the **Save in Command File** or **Export** command is used. To apply the settings to the printer, or to save or export them, make sure you clear the check box.

9. Settings Tabs

Contains settings that may be specified or changed. If  appears in the tab, the settings are not applied to the printer.

10. Printer

Lists the connected printers.

Menu Bar

File Menu Options

- **Apply Settings to the Printer**

Applies the settings to the printer.

- **Save Settings in Command File**

Saves the specified settings in a command file. The file extension is BIN. The saved command file can be used with the mass storage mode to apply the settings to a printer.



- If the **Disable these settings** check box is selected, the settings are not saved.
- The following information is not saved with the command file:
 - Node name
 - IP address, subnet mask, and default gateway (when the IP address is set to **STATIC**)
- The saved communication settings commands are intended to be used only for applying settings to a printer. To apply the settings to the printer using this command file, use the mass storage mode.
- Saved command files contain authentication keys and passwords. Take necessary measures to protect saved command files, such as saving them in a location that cannot be accessed by other users.
- Do not send command files to a different printer model.

- **Install Certificates**

Some network authentication methods may require a certificate.

Install a certificate on the connected printer or save a certificate as a command file that can be distributed to the same printer models.

- **Import**

- **Import from the current computer wireless settings (RJ-3250WB)**

Imports the settings from the computer.



- When importing the computer's wireless settings, administrator privileges for the computer are needed.
- Only personal security authentication settings (open system, public key authentication, WPA/WPA2-PSK, and WPA3 SAE up to 63 characters) can be imported. Enterprise security authentication (such as EAP-FAST), WPA2-PSK (TKIP) and WPA-PSK (AES) settings cannot be imported.
- If multiple wireless LANs are enabled for the computer you use, the first detected wireless settings (only personal settings) are considered for the import data.
- Only the settings from the **Wireless LAN** tab - **Wireless Settings** pane can be imported (communication mode, SSID, authentication method, encryption mode and authentication key).

- **Select a Profile to import**

Imports the exported file and applies the settings to a printer. Click **Browse** and select the file you want to import. The settings in the selected file appear in the settings display/change area.



- All settings can be imported, except for node names.
- Only the profiles compatible with the selected printer can be imported.
- If the imported profile's IP address is set to **STATIC**, change the IP address of the imported profile, if needed, so that it does not duplicate the IP address of an existing configured printer on the network.

• **Export**

Saves the current settings in a file. If the **Disable these settings** check box is selected, the settings are not saved.



Exported files are not encrypted.

Tools Menu Options

• **Option Settings**

- **Automatically restart the printer after applying new settings**

If this check box is selected, the printer automatically restarts after communication settings are applied. If this check box is cleared, you must restart the printer manually.



When configuring multiple printers, you can reduce the time needed to change settings by clearing this check box. In this case, we recommend selecting this check box when configuring the first printer so that you can confirm that each setting is operating as intended.

- **Automatically detects the connected printer, and retrieves the current settings**

If this check box is selected and a printer is connected to the computer, the printer is automatically detected and the printer's current settings are displayed in the **Current Status** pane.



If the connected printer is different from the printer shown in the **Printer** drop-down list, the settings available on all tabs change to match the connected printer.

• **Change Node Name/Bluetooth Device Name**

Allows renaming a node name and Bluetooth device name.

• **Reset to Default Communication Settings**

Returns the communication settings to their factory settings.

Help Menu Options

• **Display Help**

Displays the Help topics.

General Tab

Communication Settings

• **Network Settings on Power On** (RJ-3250WB)

Specifies the conditions for connecting via network when the printer is turned on. Select the **Wireless LAN by Default**, **Wired LAN by Default**, or **Keep Current State** option.

• **Selected Interface** (RJ-3250WB)

Selects the **Infrastructure**, **Infrastructure and Wireless Direct**, or **Wireless Direct** option.

- **While cradled connect using wired LAN (turns off Wi-Fi infrastructure)**

This setting will override any machine configuration that is set on the printer.

- **Bluetooth on Power On**

Specifies the conditions for connecting via Bluetooth when the printer is turned on. Select the **On by Default**, **Off by Default**, or **Keep Current State** option.

IPv6

- **IPv6 usage**

Select **Enable** or **Disable**.

- **Priority on IPv6 address**

Select to give priority to an IPv6 address.

Remote Update

- **IP Address of FTP server**

Type the FTP server address.

- **Port**

Specifies the port number used to access the FTP server.

- **User name**

Type a user name that has permission to log in to the FTP server.

- **Password**

Type the password associated with the user name you entered in the **User name** field.

- **Path**

Type the path to the folder on the FTP server where you want to download the update file from.

- **Setting file name**

Specifies the update file name on the FTP server.

Log

- **Log storage**

Select whether to export the update log to the FTP server.

- **Log storage path of FTP server**

Type the path to the folder on the FTP server where you want to export the log data.

NFC Pairing Settings

Establish a Bluetooth or Wireless Direct connection using the NFC function.

Wired LAN/Wireless LAN Tabs (RJ-3250WB)Wired LAN Tab(RJ-3230B)

TCP/IP TCP/IP (Wireless)

- **Boot Method**

Select the **AUTO**, **BOOTP**, **DHCP**, **RARP**, or **STATIC** option.

- **IP Address/Subnet Mask/Gateway**

Specifies the various networking values. You can enter these settings only when the IP address is set to **STATIC**.

- **DNS Server Method**

Select the **AUTO** or **STATIC** option.

- **Primary DNS Server IP Address/Secondary DNS Server IP Address**

Enter these settings only when the DNS server is set to **STATIC**.

IPv6

- **Static IPv6 Address**

Specifies a permanent IPv6 address.

- **Enable this address**
Enables the specified static IPv6 address.
- **Primary DNS Server IPv6 Address/Secondary DNS Server IPv6 Address**
Specifies the DNS server IPv6 addresses.
- **IPv6 Address List**
Displays the list of IPv6 addresses.

Wired 802.1x Authentication

Configures IEEE 802.1x authentication.

- **Wired 802.1x Status**
Enable or disable IEEE 802.1x authentication for wired networks.
- **Authentication Method**
Select the authentication method.
- **User ID/Password**
Specify these settings only when EAP-MD5, EAP-FAST, PEAP, EAP-TTLS, or EAP-TLS is selected as the authentication method. In addition, with EAP-TLS, it is not necessary to register a password, but a client certificate must be registered. To register a certificate, connect to the printer from a web browser, and then specify the certificate. Installation of the authentication certificate can also be performed with the Printer Setting Tool by going to the menu bar: **File > Install Certificates**.

Wireless Settings

- **Communication Mode**
Displays the available communications modes.
- **SSID (Network Name)**
Clicking **Search** displays the available SSIDs in a separate dialog box.
- **Channel**
Displays the automatically selected channel.
- **Authentication Method/Encryption Mode**
The supported encryption modes for the authentication methods are shown in the table below.

Authentication Method	Encryption Mode
Open System	None / WEP
Shared Key	WEP
WPA3-SAE	AES
WPA/WPA2-PSK/WPA3-SAE	TKIP+AES / AES
EAP-FAST/NONE	TKIP+AES / AES
EAP-FAST/MS-CHAPv2	TKIP+AES / AES
EAP-FAST/GTC	TKIP+AES / AES
PEAP/MS-CHAPv2	TKIP+AES / AES
PEAP/GTC	TKIP+AES / AES
EAP-TTLS/CHAP	TKIP+AES / AES
EAP-TTLS/MS-CHAP	TKIP+AES / AES
EAP-TTLS/MS-CHAPv2	TKIP+AES / AES
EAP-TTLS/PAP	TKIP+AES / AES
EAP-TLS	TKIP+AES / AES



To specify higher level security settings: When performing certificate verification with the EAP-FAST, PEAP, EAP-TTLS, or EAP-TLS authentication methods, the certificate cannot be specified from the Printer Setting Tool. After the printer is configured to connect to the network, specify the certificate by accessing the printer from a web browser. Installation of the authentication certificate can also be performed with the Printer Setting Tool by going to the menu bar: **File > Install Certificates**.

- **WEP Key**
Specify a setting only when WEP is selected as the encryption mode.
- **Passphrase**
Specify a setting only when WPA2-PSK, WPA3-SAE, WPA/WPA2-PSK, or WPA/WPA2-PSK/WPA3-SAE is selected as the authentication method.
- **User ID/Password**
Specify these settings only when EAP-FAST, PEAP, EAP-TTLS or EAP-TLS is selected as the authentication method. In addition, with EAP-TLS, it is not necessary to register a password, but a client certificate must be registered. To register a certificate, connect to the printer from a web browser, and then specify the certificate.
- **Display the key and password on-screen**
If this check box is selected, keys and passwords are displayed in plain (non-encrypted) text.

Wireless Direct Tab (RJ-3250WB)

Wireless Direct Settings

- **SSID/Network Key Generation**
Select the **AUTO** or **STATIC** option.
- **SSID (Network Name)/Network Key**
Specifies the SSID (25 ASCII characters or fewer) and the Network Key (63 characters or fewer) you want to use in the Wireless Direct mode.



- The default SSID and Password are as follows:
 - SSID: "DIRECT-*****_RJ-3250WB" where ***** is the last five digits of the printer's serial number.
 - Password: 325***** where ***** is the last five digits of the printer's serial number.
- The serial number label is located on the base of the printer.

- **Channel**
Specifies the channel to use for the Wireless Direct mode.

Bluetooth Tab

Bluetooth Settings

Bluetooth Mode

Selects the control mode when Bluetooth is enabled.

Classic

- **Visible to Other Devices**
Allows the printer to be "discovered" by other Bluetooth devices.
- **Change PIN code**
Changes the PIN.
- **Display the PIN code on-screen**
Displays the PIN on your computer.
- **Pairing requires user confirmation on printer**
If this check box is selected when using Classic Bluetooth mode, it is necessary to perform additional printer button operations when pairing with devices running Bluetooth 2.1 or later.
- **Auto re-pairing**

Sets whether to automatically reconnect to a previously connected Apple device (iPad, iPhone, or iPod touch).

Low Energy

- **Minimum Security Mode**

Select the minimum security level when using the **Low Energy Only** mode.

- **Pairing requires user confirmation on printer**

If this check box is selected when using the **Low Energy Only** mode, it is necessary to perform additional printer button operations when pairing with Low Energy compatible devices.



Related Information

- [Change Printer Settings Using the Printer Setting Tool \(Windows\)](#)
-

Device Settings of the Printer Setting Tool (Windows)

Use **Device Settings** in the Printer Setting Tool to specify or change printer settings when connecting the printer and computer with a USB cable or via a Bluetooth connection. Not only can you change the device settings for one printer, but you can also apply the same settings to multiple printers. When printing from a computer application, various printing settings can be specified from the printer driver; however, using the Device Settings tool in the Printer Setting Tool, more advanced settings can be specified. When you open the **Device Settings** window, the printer's current settings are retrieved and displayed. If the current settings cannot be retrieved, the previous settings are displayed. If the current settings cannot be retrieved and previous settings were not specified, the machine's factory settings appear.

>> [Settings Dialog Box](#)

>> [Menu Bar](#)

>> [Basic Tab](#)

>> [Advanced Tab](#)

>> [Print Position / Sensors Tab](#)

>> [Display Settings Tab](#)

>> [Management Tab](#)

Settings Dialog Box

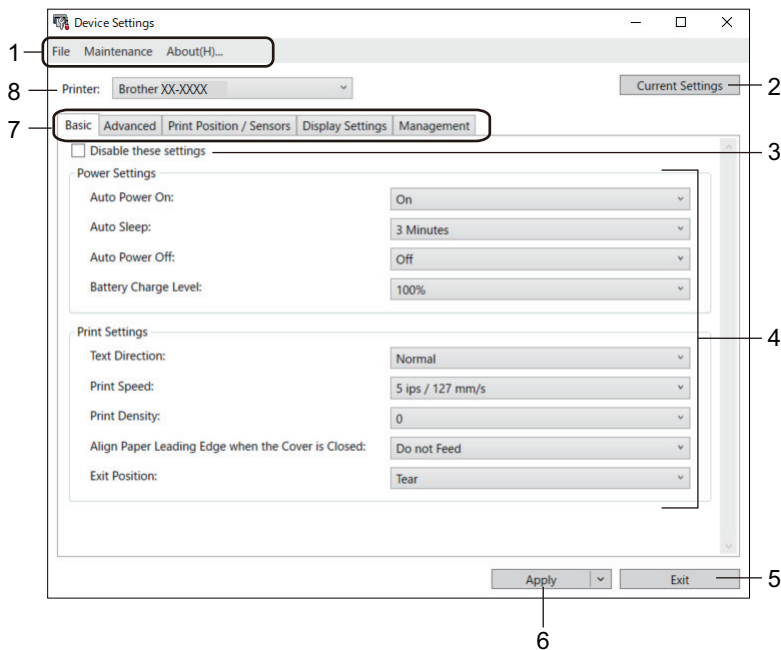



1. Menu Bar

Provides access to various commands grouped under each menu title (the **File**, **Maintenance**, and **About** menus) according to their functions.

2. Current Settings

Retrieves the settings from the currently connected printer and displays them in the dialog box. Settings can also be retrieved for the parameters on tabs with .

3. Disable these settings

When this check box is selected,  appears on the tab, and the settings can no longer be specified or changed. Settings in a tab where  appears are not applied to the printer even if **Apply** is clicked. In addition, the settings in the tab are not saved or exported when you use the **Save in Command File** or **Export** command.

4. Parameters

Displays the current settings.

5. Exit

Exits the **Device Settings** window and returns to the main window of the Printer Setting Tool.

6. Apply

Applies the settings to the printer. To save the specified settings in a command file, select the **Save in Command File** command from the drop-down list.

The saved command file can be used with the mass storage mode to apply the settings to a printer.

7. Settings Tabs

Contains settings that may be specified or changed.



If  appears in the tab, the settings cannot be changed. In addition, the settings in the tab are not applied to the printer even if you click **Apply**. The settings in the tab are not saved or exported when you use the **Save in Command File** or **Export** commands.

8. Printer

Specifies the printer you want to configure.

Menu Bar

File Menu Options

- **Apply Settings to the Printer**
Applies the settings to the printer.
- **Check Setting**
Displays the current settings.
- **Save Settings in Command File**
Saves the specified settings in a command file.
- **Import**
Imports an exported file.
- **Export**
Saves the current settings in a file.
- **Exit**
Exits the **Device Settings** window and returns to the main window of the Printer Setting Tool.

Maintenance Menu Options



You must have administrator privileges for the computer or the printer to display some items. Check if you have administrator privileges for the printer by clicking the **Printer properties** menu, and then clicking the **Security** tab.

- **Save Print Log in File**
Saves the print log in a file in the CSV format.
- **Print Unit Settings**
Prints a report containing the current firmware version and device setting information.



When you print this report, we recommend using a 2.4" (62 mm) or wider media.

- **Reset to Factory Defaults**
Resets all the settings to the factory settings, including device settings, transferred data, and network settings.
- **Reset only Device Settings**
Resets the settings that can be changed in the Device Settings to the factory settings.
- **Delete Template and Database**
Deletes the templates and databases stored in the printer.

- **Delete Print Log**

Deletes the print log stored in the printer.

- **Option Settings**

If the **Do not display an error message if the current settings cannot be retrieved at startup** check box is selected, a message is not displayed the next time.

Basic Tab

- **Auto Power On**

Specifies whether the printer turns on automatically when the AC Power Cord is plugged into an AC power outlet.

- **Auto Sleep**

Specifies the amount of time to pass before the printer automatically goes into sleep mode.



- The printer will automatically enter sleep mode when the specified time elapses under the following conditions:

- The printer does not receive data.
- In idle mode.

- Sleep mode is cancelled when the following operations are performed:

- A printer button is pushed.
- The Roll Compartment Cover is opened or closed.
- The printer receives data.
- The USB cable is disconnected and then reconnected.

- **Auto Power Off**

Specifies the period of time that passes before the printer turns off automatically.



- The printer will automatically enter power off mode when the specified time elapses under the following conditions:

- The printer does not receive data.
- In idle mode.

- Power off mode is cancelled when the following operations are performed:

- A printer button is pushed.
- The Roll Compartment Cover is opened or closed.
- The printer receives data.
- The USB cable is disconnected and then reconnected.

- **Battery Charge Level**

Specifies the maximum charge level.



To get the longest life from the battery, select **80 %**. Although the number of print jobs that can be printed on a single charge will be less when you select **80 %**, you can get a longer overall battery life.

- **Text Direction**

Selects the printing orientation.

- **Print Speed**

Selects the printer's printing speed.

- **Print Density**

Adjusts the printer's printing density.

- **Cover Closed Setting**

Selects the printer's action when the cover is closed.

- **Select Media**

Shows the [Select Media] screen for ten seconds after you close the Roll Compartment Cover.

- **Feed**

Feeds the label automatically when you close the Roll Compartment Cover.

- **Auto Detect**

Performs **Auto Detect** automatically when you close the Roll Compartment Cover. The printer displays the detected paper size, and then displays the Ready screen.

- **None**

No action and no change on the LCD.

- **Exit Position**

Selects the media output location.

Advanced Tab

- **Feed Key Function**

Selects the operation performed when  is pressed. If **Program Settings** is selected, click **File** and select the command file.

- **Menu Key Function**

Selects the operation performed when **Menu / ▼** (Select) button is pressed. If **Program Settings** is selected, click **File** and select the command file.

- **Print Information Report**

Selects the information you want to include in the printer Information Report.

- **JPEG Printing Setting**

Selects the method of image processing when printing JPEG images.

- **Serialize Mode**

Specifies the serialize (number) method for your printed labels.

- **Save Printer Print Log**

Selects whether to save the printer's print log. If **Disable** is selected, the **Save Print Log in File** option cannot be enabled.

- **Print Data after Printing**

Specifies whether print data is erased after printing.

- **Linerless**

Selects to enable support for Linerless rolls.

Print Position / Sensors Tab

When you use standard media, it is unnecessary to adjust the sensors.

- **Printing Reference Point Adjustment**

Adjusts the position of the reference point (point of origin for printing). This corrects printing misalignments resulting from differences in printer models or from the fixed margins of some software.

The reference point cannot be adjusted for raster printing.

- **Tear Adjust**

- Adjusts the tear bar tear-off position for paper media.

NOTE

Depending on the media type, the cut position and margins may not match your settings. If this occurs, adjust the Tear Adjust setting, and then try to print again.

- When **Use Peeler Function** is enabled and the peeled labels are jammed or are not ejected correctly after printing, adjust the Tear Adjust setting, and then try to print again.

-
- **Media Sensor (Transmissive/Gap)**
 - **Detection Sensitivity**
Adjusts the sensitivity of gap (spacing) detection for die-cut labels.
 - **Luminescence Adjustment**
Adjusts the amount of light emitted by the transmissive/gap sensor.
 - **Media Sensor (Reflective/Bar)**
 - **Mark Detection Sensitivity**
Adjusts the sensitivity of black mark detection.
 - **Luminescence Adjustment**
Adjusts the amount of light emitted by the reflective/black mark sensor.
 - **Media Sensor (Peeler)**

Specifies the settings when the Label Peeler (optional) is used.

 - **Detection Sensitivity**
Adjusts the precision of the sensor that detects whether the label has been peeled.

Display Settings Tab

- **Clock**
Sets the clock function.
- **Synchronize with SNTP server**
Synchronizes time with the SNTP server.
- **Time Zone**
Sets the time zone.
- **Set Clock**
Sets the date and time.
- **LCD Contrast**
Sets the contrast of the LCD.
- **Backlight Timeout**
Sets the period of time before the backlight turns off if the printer is not used.
- **Beeper**
Select whether the printer beeps when it is turned on or off, or if an error occurs.

Management Tab



To display this tab, you must have administrator privileges for the computer or the printer. Check if you have administrator privileges for the printer by clicking the **Printer properties** menu, and then clicking the **Security** tab.

- **Language**
Specifies the language displayed on the LCD.
- **Airplane Mode (RJ-3250WB)**
Allows disabling the Bluetooth or Wi-Fi interfaces. This function is useful when you use the printer in a place where signal transmissions are not allowed.
- **Command Mode**
Selects the command mode type.

✓ Related Information

- [Change Printer Settings Using the Printer Setting Tool \(Windows\)](#)

P-touch Template Settings of the Printer Setting Tool (Windows)

P-touch Template mode allows you to insert data into text and barcode objects from a downloaded template using other devices connected to the printer. The available options and supplies may vary depending on your country. Use P-touch Template Settings in the Printer Setting Tool to specify or change P-touch Template functions.



- P-touch Template mode is also compatible with other input devices like a scale, testing machine, controller, or a programmable logic device.
- For more information on P-touch Template Settings, see the *P-touch Template Manual/Command Reference* (English only). You can download the latest version from the Brother support website at support.brother.com/manuals.

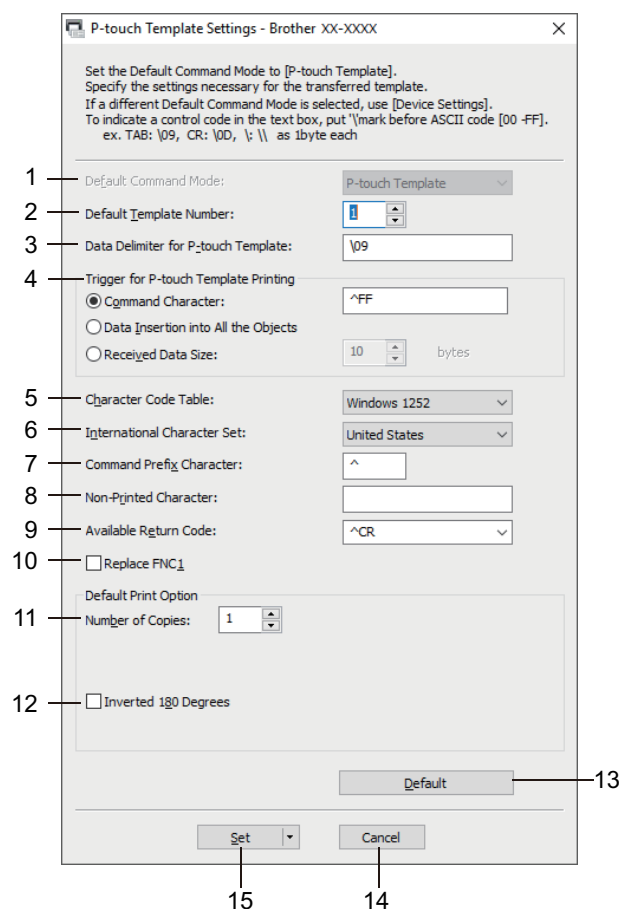

1. Default Command Mode

Specifies the P-touch Template mode as the default mode. To change the mode, select the mode by accessing the **Management** tab in the **Device Settings** window.

2. Default Template Number

Specifies a default template number that the printer sets when it is turned on. If you do not want to transfer a template to the printer, do not specify a template number.

3. Data Delimiter for P-touch Template

Displays a symbol used to indicate the boundaries between groups of data in a file (maximum of 20 characters).

4. Trigger for P-touch Template Printing

Specifies a trigger to begin printing from a number of options.

- **Command Character:** Printing starts when the command character specified here is received.
- **Data Insertion into All the Objects:** Printing starts when the delimiter for the last object is received.

- **Received Data Size:** Printing starts when the number of characters specified here is received. However, delimiters are not counted in the number of characters.

5. Character Code Table

Selects one of the character code sets.

6. International Character Set

Lists character sets for specific countries. The following codes vary depending on the selected country:

23h 24h 40h 5Bh 5Ch 5Dh 5Eh 60h 7Bh 7Ch 7Dh 7Eh

To change the characters, see the *P-touch Template Manual/Command Reference* (English only). You can download the latest version from the Brother support website at support.brother.com/manuals.

7. Command Prefix Character

Specifies the prefix character code identifying commands used in P-touch Template mode.

8. Non-Printed Character

Characters specified here are not printed when data is received (maximum of 20 characters).

9. Available Return Code

The line feed code is used when feeding data to indicate that the following data should be moved to the next line in a text object. Select one of four line feed codes or type the line feed code you want (maximum of 20 characters).

10. Replace FNC1

Replaces GS codes with FNC1.

11. Number of Copies

Sets the number of copies (maximum of 99 copies).

12. Inverted 180 Degrees

If this check box is selected, the data will be printed after it has been rotated 180 degrees.

13. Default

Returns all setting values in the P-touch Template Settings dialog box to the default values.

14. Cancel

Cancels the settings and closes the dialog box. The settings remain unchanged.

15. Set

Applies the settings to the printer. To save the specified settings to a command file to reuse in the future, select the **Save in Command File** command from the drop-down list.

The saved command file can be used with the mass storage mode to apply the settings to a printer.



Related Information

- [Change Printer Settings Using the Printer Setting Tool \(Windows\)](#)

Related Topics:

- [Print Using the USB Interface \(Mass Storage Mode\)](#)

The Paper Size Setup Feature of the Printer Setting Tool (Windows)

Use the Paper Size Setup in the Printer Setting Tool to add paper sizes not available in the **Paper Size** list of the printer driver.

Before you print using a paper size other than the available ones, you must register the new paper size by sending it to the printer.

Printing with a paper size not registered with the printer may produce incorrect print results.

Paper Size Setup Dialog Box

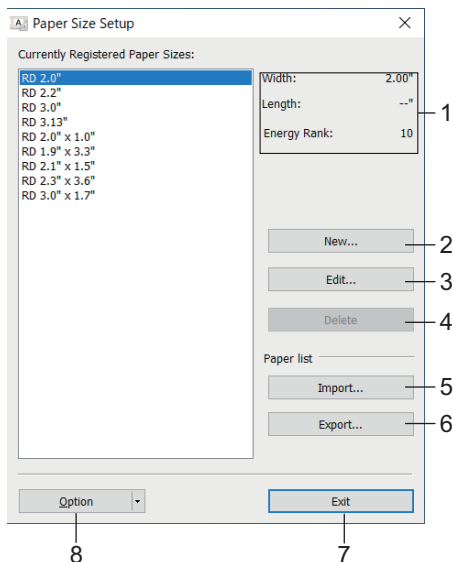

1. Current settings

Displays the current settings for the selected paper format.

2. New

Click this button to display the **New** dialog box and register a new paper size.

NOTE

Do not register a paper size already registered, to avoid incorrect print results. To use paper of the same size as one that is currently registered, select the size you want from the **Currently Registered Paper Sizes** list in the **Paper Size Setup** dialog box, and then change and overwrite the settings from the **Edit** dialog box.

3. Edit

Edits the settings for the selected paper format.

To save the selected paper format with the new settings, click **Overwrite**. To add a paper format with the new settings, change the name in the **Paper Size Name** box, and then click **Add**.

4. Delete

Deletes the selected paper format. A deleted paper format cannot be restored.

5. Import

Reads the text file containing the paper format settings and uses it to replace the contents of the **Currently Registered Paper Sizes** list.

NOTE

When the list is imported, the entire contents of the **Currently Registered Paper Sizes** list will be replaced with the imported paper formats.

6. Export

Exports the paper formats in the **Currently Registered Paper Sizes** list to a file. The exported formats can then be distributed to other computers.

7. Exit

Exits the **Paper Size Setup** window and returns to the main window of the Printer Setting Tool.

8. Option

Click ▼, and then select an operation.

Click **Register Paper Size With Printer** to register the settings for the selected paper format in the printer.

Click **Save in Command File** to export the paper settings as a command file. (The file extension is BIN.)

NOTE

When the paper format is registered with the printer and **Exit** is clicked, the **Paper Size Setup** dialog box appears with the added paper size in the **Currently Registered Paper Sizes** list. If the software is running, exit the software, and then restart it for the new paper format to appear in the list.



- If the following functions are being used, you can quickly apply their settings to the printer:
 - Mass storage feature
 - Bluetooth (Object Push Profile (OPP))
 - Wi-Fi (File Transfer Protocol (FTP)) (RJ-3250WB)
- These commands are only intended to be used to apply settings to a printer. These commands cannot be imported into the Paper Size Setup.

>> [New Dialog Box](#)

>> [Advanced Printing Adjustments Dialog Box](#)

New Dialog Box

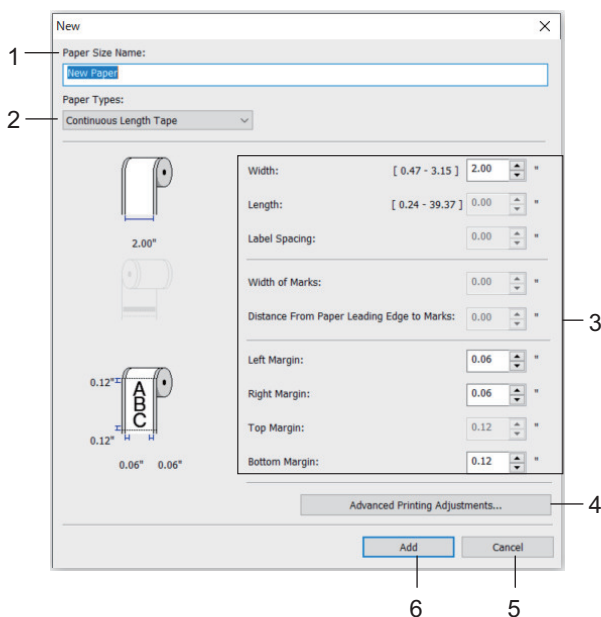

1. Paper Size Name

Type in the name of the paper format to be added.

2. Paper Types

Select the paper type.

3. Detailed settings

Specify details for the paper format to be added.

4. Advanced Printing Adjustments

Click this button to display the **Advanced Printing Adjustments** dialog box and make advanced printing adjustments for each paper format.

5. Cancel

Cancels the settings and closes the dialog box. The settings will remain unchanged.

6. Add

Click this button to add the paper format and apply the settings.

Advanced Printing Adjustments Dialog Box

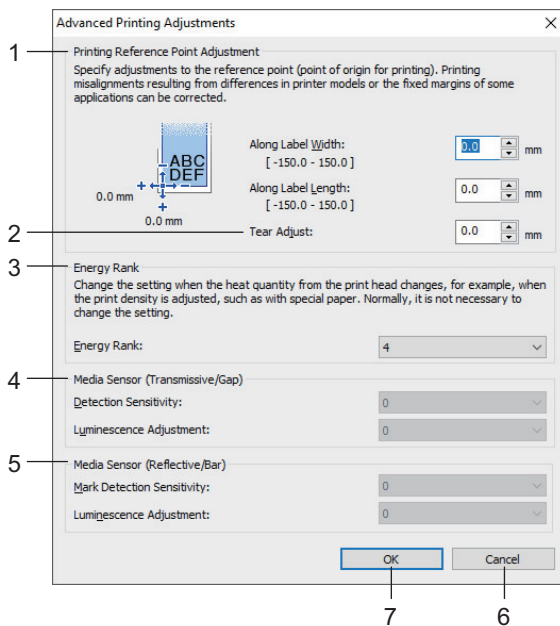

1. Printing Reference Point Adjustment

Adjust the position of the reference point (point of origin for printing). This corrects printing misalignments resulting from differences in printer models or from the fixed margins of some software.

2. Tear Adjust

Adjust the cutting position when the paper is cut using the Tear Bar.

3. Energy Rank

Adjust the amount of heat (energy) from the print head, for example, with special paper.



There may be contrast variations in the print result due to the operating environment and media used. Modify the settings as necessary.

4. Media Sensor (Transmissive/Gap)

Adjust the precision with which the transmissive/gap sensor detects the gaps (spacing) for die-cut labels and the amount of light emitted by the sensor.

Settings can be specified when **Paper Types** is set to **Die-cut Label**.



The settings for **Media Sensor (Transmissive/Gap)** in the **Device Settings** dialog box can influence the detection and calibration results. Make sure you specify the appropriate values.

Example settings:

	Setting EX1	Setting EX2
Device Settings	+2	-2
Paper Size Setup	+2	+2
Actual effect	4	0

5. Media Sensor (Reflective/Bar)

Adjust the precision with which the reflective/black mark sensor detects black marks and the amount of light emitted by the sensor.

Settings can be specified when **Paper Types** is set to **Media With Marks**.



The settings for **Media Sensor (Reflective/Bar)** in the **Device Settings** dialog box can influence the detection and calibration results. Make sure you specify the appropriate values.

Example settings:

	Setting EX1	Setting EX2
Device Settings	+2	-2
Paper Size Setup	+2	+2
Actual effect	4	0

6. Cancel

Cancels the settings and closes the dialog box. The settings will remain unchanged.

7. OK

Saves the settings and returns to the previous dialog box.



Related Information

- [Change Printer Settings Using the Printer Setting Tool \(Windows\)](#)
 - [Distribute Paper Formats to Other Computers \(Windows\)](#)

Distribute Paper Formats to Other Computers (Windows)

The paper formats exported from the **Currently Registered Paper Sizes** list in the **Paper Size Setup** dialog box can be distributed to other computers. If the printer driver has been installed on the recipient's computer, only the paper formats need to be distributed.

1. At the sender's computer, specify the paper format settings, and then click **Export**.

The following files are created:

RJ-3230B	bsr323ed.ptd bsr323ed.txt pdt4537.bin
RJ-3250WB	bsr325ed.ptd bsr325ed.txt pdt4637.bin

2. Save the TXT file in any location on the recipient's computer.
3. At the recipient's computer, click **Import**.

The paper formats are replaced with the imported ones.

Related Information

- [The Paper Size Setup Feature of the Printer Setting Tool \(Windows\)](#)

Apply Setting Changes to Multiple Printers (Windows)

>> [Communication Settings](#)

>> [Device Settings](#)

Communication Settings

1. After applying settings to the first printer, disconnect the printer from the computer, and then connect the second printer to the computer.
2. Select the newly connected printer from the **Printer** drop-down list.
If the **Automatically detects the connected printer, and retrieves the current settings** check box in the **Option Settings** dialog box is selected, the printer connected with the USB cable is automatically selected.
3. Click **Apply**.
(RJ-3250WB) We recommend selecting the **Automatically restart the printer after applying new settings** check box when configuring the first printer so that you can confirm that the printer can be correctly connected to the wireless router/access point with the new settings.
The same settings that were applied to the first printer are applied to the second printer.
4. Repeat these steps for all printers whose settings you want to change.



- If the IP address is set to **STATIC**, the printer's IP address is changed to the same address as the first printer. Change the IP address if needed.
- The same settings can be applied to another computer by clicking **File > Import**, and then selecting the exported settings file.

Device Settings

1. After applying settings to the first printer, disconnect the printer from the computer, and then connect the second printer to the computer.
2. Select the newly connected printer from the **Printer** drop-down list.
3. Click **Apply**.
The same settings that were applied to the first printer are applied to the second printer.
4. Repeat these steps for all printers whose settings you want to change.



The same settings can be applied to another computer by clicking **File > Import**, and then selecting the exported settings file.

✓ Related Information

- [Printer Settings](#)

Change Printer Settings Using Web Based Management

You can use a standard web browser to change your printer's settings using the Hyper Text Transfer Protocol (HTTP) or Hyper Text Transfer Protocol over Secure Socket Layer (HTTPS).

When using Web Based Management, the following operations are available:

- Displaying your printer status information
- Changing network settings, such as TCP/IP information
- Displaying the printer's software version information
- Changing network and printer configuration details



- We recommend Microsoft Internet Explorer 11/Microsoft Edge for Windows. Make sure that JavaScript and Cookies are always enabled in whichever browser you use.
- The default login password to manage printer settings is located on your machine and marked "Pwd". We recommend you change it to protect your printer from unauthorized access.

To use Web Based Management, your network must use TCP/IP, and the printer and computer must have a valid IP address.

1. Start your web browser.
2. Type "https://machine's IP address" in your browser's address bar (where "machine's IP address" is the machine's IP address).

For example:

https://192.168.1.2



If you are using a Domain Name System or enable a NetBIOS name, you can type another name, such as "SharedPrinter" instead of the IP address.

- For example:

https://SharedPrinter

If you enable a NetBIOS name, you can also use the node name.

- For example:

https://brnxxxxxxxxxxxx

3. If the machine prompts you for a password, type it, and then click **Login**.
4. Change the printer settings.

Every time you access Web Based Management, type the password in the **Login** field, and then click **Login**.

After configuring the settings, log out by clicking **Login**.



Related Information

- [Printer Settings](#)
 - [Set or Change a Login Password for Web Based Management](#)

Set or Change a Login Password for Web Based Management

We recommend changing the default login password to prevent unauthorized access to Web Based Management.

1. Start your web browser.
2. Type "https://machine's IP address" in your browser's address bar (where "machine's IP address" is the machine's IP address).

For example:

https://192.168.1.2



If you are using a Domain Name System or enable a NetBIOS name, you can type another name, such as "SharedPrinter" instead of the IP address.

- For example:

https://SharedPrinter

If you enable a NetBIOS name, you can also use the node name.

- For example:

https://brnxxxxxxxxxxxx



3. Do one of the following:
 - If you have previously set your own password, type it, and then click **Login**.
 - If you have not previously set your own password, type the password located on your machine and marked "Pwd", and then click **Login**.
4. Click the **Administrator** tab.
5. Type the password you want to use in the **Enter New Password** field (up to 32 characters).
6. Re-type the password in the **Confirm New Password** field.
7. Click **Submit**.



Related Information

- [Change Printer Settings Using Web Based Management](#)

Change Printer Settings Using the Printer

1. Press the **Menu** / ▼ (Select) button to select the menu option, and then press the  (Feed) / **OK** button.
2. Press the **Menu** / ▼ (Select) button to select an option, and then press the  (Feed) / **OK** button. .



- a. The current selection is highlighted.
- b. The scroll bar shows the position of the highlighted option on the list.

 You can also change the printer settings using the Printer Setting Tool on a computer connected to the printer.

Related Information

- [Printer Settings](#)
 - [Settings Tables](#)

Related Topics:

- [Change Printer Settings Using the Printer Setting Tool \(Windows\)](#)

Settings Tables

The Settings tables describe the menu selections and options.



Some settings may differ depending on the firmware (printer software) version.

- >> [WLAN]
- >> [Bluetooth]
- >> [Wired LAN]
- >> [Media]
- >> [Settings]

[WLAN]

Level 1	Level 2	Descriptions
On/Off	On / Off	Turn the WLAN function on or off.
Mode	Direct / Infrastructure / Direct / Infra	Select the network mode when you set the WLAN function to on.
WPS	Button Push / PIN Code	Select the WPS network settings method.
WLANAssistant	Start / Back	Use the WLAN connection assistant function to configure your wireless network settings.
IP Address		Display the IP Address.

[Bluetooth]

Level 1	Level 2	Descriptions
On/Off	On / Off	Turn the Bluetooth function on or off.
Mode	Classic & LE / Classic / Low Energy	Select the Bluetooth mode.
AutoReconnect	On / Off	Switch to Automatic Reconnection mode (only for Apple devices: iPad, iPhone, or iPod touch).
Clear History		Delete the information for auto re-paired devices registered in the printer.
BT Address		Display the Bluetooth address.
Print Barcode		Print the Bluetooth address and corresponding barcode.

[Wired LAN]

Level 1	Level 2	Descriptions
Cradle LAN	On / Off	Select the wireless (infrastructure) or wired connection when the printer is placed on the Active Docking Station.
IP Address		Display the IP Address.

[Media]

Level 1	Level 2	Descriptions
Select Media	-	Select the paper size and paper type or check the current paper size setting. The list contains: <ul style="list-style-type: none"> • Default media (Nine types. Default: 3.0" x 1.7" (76 mm x 44 mm)) • User-defined media (Ten types)

Level 1	Level 2	Descriptions
		<ul style="list-style-type: none"> Auto-detected media Media settings obtained using the <code>Auto Detect</code> function.
Auto Detect	-	Automatically adjust the sensor sensitivity and detect the length of the set paper. Specify <code>Settings</code> in advance.
Settings ¹	-	Configure the settings before performing <code>Auto Detect</code> .
	Width	Select the paper width to be auto-detected.
	Sensor Type	Select the sensor type: Die-cut, Mark, or Continuous.
	Sensor Calibr	Enable or disable sensor calibration during auto-detection.
	Media Timeout	Set the auto-detected paper to <code>Continuous</code> if <code>Auto Detect</code> does not find any gap or black mark according to the <code>Media Timeout</code> length.
	Energy Rank	Select the energy rank to adjust the print density.

¹ Requires from the firmware version 1.09 or later.

[Settings]

Level 1	Level 2	Descriptions
Exit Position	Tear / Peeler	Select the media exit method.
Language	Dansk / Deutsch / English / Español / Français / Italiano / Nederlands / Norsk / Português / Suomi / Svenska / 日本語 / 繁體中文	Select the language.
LCD Contrast	+2 / +1 / 0 / -1 / -2	Set the contrast of the LCD. The higher the number, the stronger the contrast.
Beeper	On / Off	Enable or disable the beeper.
Configuration		Check the firmware version, font version, and available memory.
Tear Bar	Upward / Downward	Adjust the tear position. This setting appears when the Linerless is set to Off in the Advanced tab of the Printer Setting Tool.
Cover Setting ¹	Select Media	Shows the <code>Select Media</code> screen for ten seconds after you close the Roll Compartment Cover.
	Feed	Feeds the label automatically when you close the Roll Compartment Cover.
	Auto Detect	Performs Auto Detect automatically when you close the Roll Compartment Cover. The printer displays the detected paper size, and then displays the Ready screen.
	None	No action and no change on the LCD.
Clock	On / Off	Show or hide the clock icon on the LCD.
AutoSync Time	On / Off	This setting appears when <code>Clock</code> is set to <code>On</code> .
Time Zone		Set the time zone. This setting appears when <code>Clock</code> is set to <code>On</code> .
Date&Time		Display the date and time. This setting appears when <code>Clock</code> is set to <code>On</code> .

¹ Requires from the firmware version 1.09 or later.



Related Information

- [Change Printer Settings Using the Printer](#)
-

Routine Maintenance

- [Maintenance](#)

Maintenance

Maintenance of the printer may be carried out as required. However, some environments may require more frequent maintenance (for example, dusty environments).

- >> [Clean the Printer \(Exterior\)](#)
- >> [Clean the Print Head](#)
- >> [Clean the Roller](#)
- >> [Clean the Paper Exit Slot](#)
- >> [Linerless Platen Upgrade Maintenance](#)
- >> [Label Peeler Maintenance](#)

Clean the Printer (Exterior)

- Wipe any dust and marks from the printer's exterior using a soft, dry cloth. Use a cloth slightly damp with water on difficult to remove marks.

IMPORTANT

Do not use paint thinner, benzene, alcohol, or any other organic solvent. These may deform or damage the printer.

Clean the Print Head

- Wipe the print head with a lint-free cloth dipped in isopropyl alcohol or ethanol. Carry out the maintenance frequently.

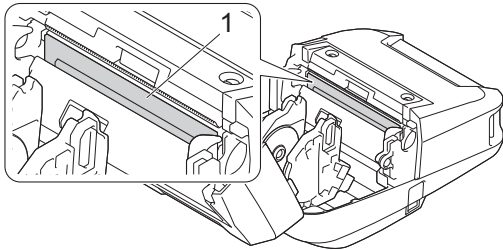

1. Print Head



Use the isopropyl alcohol or ethanol according to the manufacturer's safety guidelines, as applicable.

Clean the Roller

- Wipe the roller with a lint-free cloth dipped in isopropyl alcohol or ethanol. After cleaning the roller, make sure that no lint or other material remains on the roller.

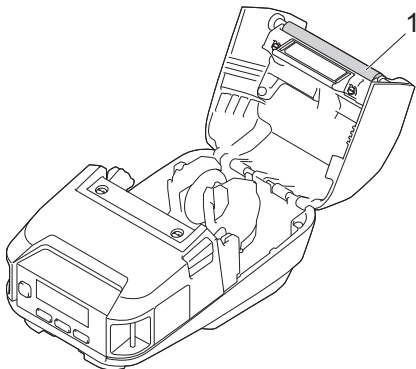

1. Roller



Use the isopropyl alcohol or ethanol according to the manufacturer's safety guidelines, as applicable.

Clean the Paper Exit Slot

- If adhesive accumulates at the paper exit slot and media becomes jammed, or if the paper exit slot becomes dirty, wipe the paper exit slot with a lint-free cloth dipped in isopropyl alcohol or ethanol.

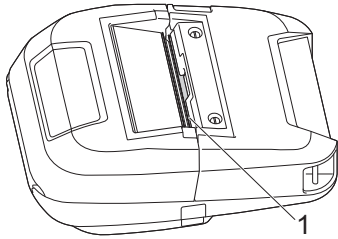

1. Paper Exit Slot



Use the isopropyl alcohol or ethanol according to the manufacturer's safety guidelines, as applicable.

Linerless Platen Upgrade Maintenance

When using the Linerless Platen Upgrade (PA-LPR-004), paper dust may stick to the print head.

- Clean the print head regularly with a lint-free cloth or cotton swab dipped in isopropyl alcohol or ethanol as shown in the illustration.

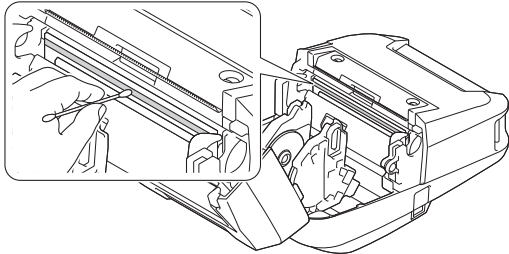

After cleaning the print head, make sure that no lint or other material remains on the print head.



- Do not clean the roller of the Linerless Platen to prevent its deterioration.
- Use the isopropyl alcohol or ethanol according to the manufacturer's safety guidelines, as applicable.

Label Peeler Maintenance

When using the Label Peeler (PA-LP-007), adhesive may accumulate at the slot and roller parts, resulting in a media jam, or the slot and roller parts may become dirty.

- Wipe the paper exit slot, peeler roller, and platen roller with a lint-free cloth dipped in isopropyl alcohol or ethanol as shown in the illustration.

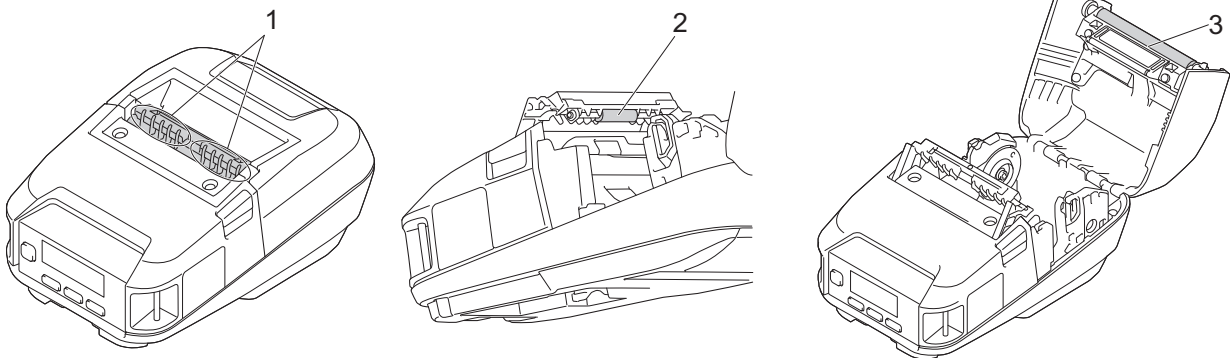

1. Paper Exit Slot
2. Peeler Roller
3. Platen Roller



Use the isopropyl alcohol or ethanol according to the manufacturer's safety guidelines, as applicable.



Related Information

- Routine Maintenance
-

Troubleshooting

- [If You Are Having Difficulty with Your Machine](#)
- [Error and Maintenance Messages](#)
- [Printing Problems](#)
- [Network Problems](#)
- [Version Information](#)
- [Reset the Printer](#)
- [Battery Charger \(Optional\) Problems](#)
- [Active Docking Station \(Optional\) Problems](#)
- [Linerless Platen Upgrade \(Optional\) Problems](#)

If You Are Having Difficulty with Your Machine

This chapter explains how to resolve typical problems you may encounter when using the printer. If you have any problems with the printer, first make sure you have performed the following tasks correctly:

- Connect the printer to a computer using a USB cable or install the battery.
- Connect the AC Adapter (Optional). For more information, see *Related Information*.
- Connect the Car Adapter (Optional). For more information, see *Related Information*.
- Remove all protective packaging from the printer.
- Install and select the correct printer driver. For more information, see *Related Topics*.
- Connect the printer to a computer or mobile device. For more information, see *Related Information*.
- Close the Roll Compartment Cover completely.
- Insert the media correctly. For more information, see *Related Information*.

If you still have problems, see *Related Information*. If after reading the topics you are unable to resolve the problem, visit the Brother support website at support.brother.com.



Related Information

- [Troubleshooting](#)

Related Topics:

- [Charge the Battery](#)
- [Install the Battery](#)
- [Connect the Printer to a Computer Using a USB Cable](#)
- [Connect the Printer to a Mobile Device Using NFC \(Android\)](#)
- [Load the Roll](#)

Error and Maintenance Messages

Error Message	Cause/Solution
Batt.VeryPoor Replace battery	The battery may be depleted. Replace the battery with a new one. Visit the Brother support website at support.brother.com .
Cannot Update Data Try updating the data again.	<ul style="list-style-type: none"> Check the FTP server setting of the Remote Update function. Make sure the setting file is stored in the specified location. Make sure the file specified by the administrator exists in the folder on the FTP server.
ChargingError Cannot Charge	Is battery charging incomplete despite continuous charging? Confirm that the battery is correctly installed. If charging is still unsuccessful, the battery may be deteriorated. Replace the battery with a new one.
Clock Not Set	Set the date and time.
Communication Error	<ul style="list-style-type: none"> Data transfer has been unsuccessful. When sending a template as a BLF file, make sure the model name listed in the file matches your printer's model name. Has the Wi-Fi or Bluetooth connection been interrupted? Turn off the printer, and then turn it on again.
Cover Open Close Cover	Is the Roll Compartment Cover open? Check that the Roll Compartment Cover is closed.
High Temp!	Is the printer temperature too high? When the Linerless rolls setting is active and the printer overheats, the error message appears. Wait until the printer cools down.
Invalid Database Record	An error will occur when printing a template which specifies an incorrect key code, or a non-existent key code in a linked database.
Low Battery!	The error message appears just before printing and when the printer cannot print because of the weak battery although the printer is connected and charged using an adapter, USB cable, or Docking Station.
Mass Storage Operation error!	Is the printer in mass storage mode? <ul style="list-style-type: none"> The printer's file system may be corrupted, or a file's name or contents were changed while the file was being transferred or processed. Turn off the printer, and then turn it on again. Do not access the files on the printer during mass storage processing to avoid further problems.
Media Error! Check Loading	<ul style="list-style-type: none"> Is the correct roll installed? Check that the correct media type (die-cut label or continuous length tape) and size is installed. Is the roll installed correctly? If not, remove the roll, and then reinstall it. For more information, see <i>Related Topics</i>. Is there enough roll remaining? If not, install a new roll.
Memory Full!	Make sure the data you transfer does not exceed the capacity of the user storage area.
No Template Selected	<ul style="list-style-type: none"> There is no template with the specified number. Specify the correct number. When printing a template, an error is indicated if the specified template does not exist. The template was not transferred. Register the template with the specified number to the printer.

Error Message	Cause/Solution
Print Data Too Large	<ul style="list-style-type: none"> The printer receives a print job exceeding the maximum print length. Print jobs exceeding 118.1" (3 m) and incompatible files cannot be printed.
Recharge Battery!	<p>Does the rechargeable battery have a low charge?</p> <p>Use the AC Adapter and AC power cord to connect the printer to an AC power outlet, or use the car adapter to connect the printer to a DC power outlet to charge the battery.</p> <p>You can also charge the battery using a USB cable (not included).</p>
System Error! XX	If the error message is displayed, contact Brother customer service.
<p>WPS did not connect 1 Try to connect again</p> <p>WPS did not connect 2 Try to connect again</p>	<p>The Wi-Fi router/access point could not be found or multiple Wi-Fi routers/access points were found.</p> <ul style="list-style-type: none"> Confirm that only one Wi-Fi router/access point within range has the WPS method active and try again. Try again after a few minutes to avoid interference from other routers/access points.



Related Information

- [Troubleshooting](#)



Related Topics:

- [Load the Roll](#)

Printing Problems

- >> Printing Problems
- >> Printed Image Problems
- >> Printer Problems

Printing Problems

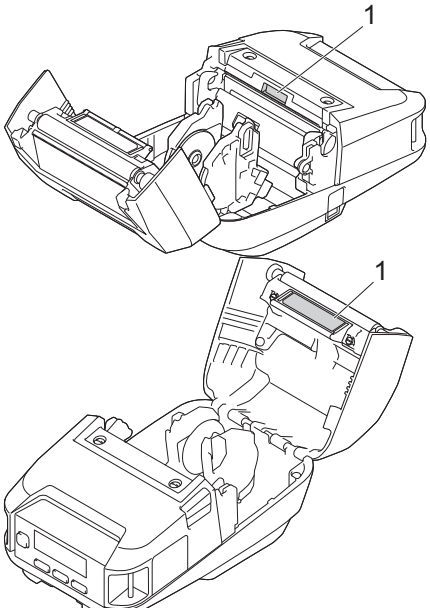
Problem	Solution
<p>The printer does not print, or there is a printing error.</p>	<ul style="list-style-type: none"> • Is the cable not fully connected (when you are using a USB cable)? Make sure the cable is connected securely. • Is the roll installed correctly? If not, remove the roll and reinstall it. For more information, see <i>Related Topics</i>. • Is there enough roll remaining? If not, install a new roll. • Is the Roll Compartment Cover open? Make sure the Roll Compartment Cover is closed. • Has a print error or transmission error occurred? Turn off the printer, and then turn it on again. If there is still a problem, contact Brother Customer Service.
<p>The printer does not feed paper.</p>	<ul style="list-style-type: none"> • Is there dirt or lint on the roller preventing it from rotating freely? Clean the roller. For more information, see <i>Related Topics</i>. • Make sure the ejection path of the paper is not blocked. • Remove the roll and install it again. For more information, see <i>Related Topics</i>. • Make sure the Roll Compartment Cover is closed completely.
<p>The printer feeds paper continuously.</p>	<ul style="list-style-type: none"> • Open the Roll Compartment Cover. • Press the  (Power) button or  (Back) button to cancel the print job. • Turn off the printer.
<p>The printer does not pause between labels.</p>	<ul style="list-style-type: none"> • Make sure you entered the media information correctly. You can set the media information using Paper Size Setup in the Printer Setting Tool. • If the sensor is dirty, wipe it with a dry cotton swab. 

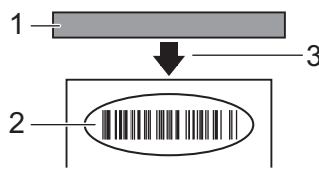

Problem	Solution
	<ol style="list-style-type: none"> Media Sensor <ul style="list-style-type: none"> Make sure there are no items blocking the sensor.
When printing via the USB cable, the printer repeatedly pauses, and then continues printing.	<p>Is the printer set for sequential printing? If so, set print mode to buffered printing.</p> <ul style="list-style-type: none"> Windows 10/Windows Server 2016/Windows Server 2019: Click Start > Settings > Devices > Printers & scanners. Click the printer you want to set up, and then click Open queue. Click Printer > Printing Preferences. Click the Other tab and select the After one page of data is received option. Windows 8.1/Windows Server 2012/Windows Server 2012 R2: Click Control Panel in the Apps screen. Click Hardware and Sound > Devices and Printers. Right-click the printer you want to set up, and then click the Printing preferences menu. Click the Other tab and select the After one page of data is received option. Windows 7: Click Start > Devices and Printers. Right-click the printer you want to set up, and then click the Printing preferences menu. Click the Other tab and select the After one page of data is received option.
An error occurs when the roll cannot be fed to the print start position.	If a feed error occurs, use the Paper Size Setup of the Printer Setting Tool to assign the correct paper settings to the printer or click Select Media to check whether correct media is set in the printer.

Printed Image Problems

Problem	Solution
Printed paper contains streaks or poor quality characters, or paper is not fed correctly.	<p>Is the print head or roller dirty?</p> <p>Although the print head generally remains clean under normal use, lint or dirt from the roller may become stuck on the printer head. If this occurs, clean the roller. For more information, see <i>Related Topics</i>.</p>
The print quality is poor.	<ul style="list-style-type: none"> Is there dust or dirt on the print head or roller preventing it from rotating freely? Clean the print head or roller. For more information, see <i>Related Topics</i>. Adjust the printing density. The print density can be specified in the Printer Setting Tool.
Printed barcodes cannot be read.	<ul style="list-style-type: none"> Print labels so that barcodes are aligned with the print head as shown below: <div style="text-align: center;">  <p>The diagram shows a horizontal grey bar labeled '1' representing the print head. Below it, a downward-pointing arrow labeled '3' indicates the direction of the print head. Underneath the arrow, a rectangular box labeled '2' contains a barcode. The barcode is centered under the arrow, indicating proper alignment.</p> </div> <ol style="list-style-type: none"> Print Head Barcodes Printing orientation Try using another barcode reader. Set Print Speed to a slower option. The print speed can be specified in the Printer Setting Tool. For more information, see <i>Related Topics</i>. Adjust Print Density. The print density can be specified in the Printer Setting Tool. For more information, see <i>Related Topics</i>. Always check that barcode labels can be read by the barcode reader.

Problem	Solution
The paper's head margin is different from the printer setting.	<ul style="list-style-type: none"> • Make sure that the Roll outside diameter is within 2.6" (66 mm). • Check that the tear position setting (Upward / Downward) is correct. • Are the correct Media Roll Holders installed in the printer?

Printer Problems

Problem	Solution
The LED indicator or the LCD is not lit.	<ul style="list-style-type: none"> • Is the battery inserted correctly? Make sure the battery is inserted correctly. If it is, check that the battery has sufficient charge remaining. • Is the adapter cord securely connected? Make sure the cord is connected correctly. • If the LED Indicator or the LCD still does not light up, contact Brother Customer Service.
A data transmission error appears on the computer.	<ul style="list-style-type: none"> • Is the correct port selected? Make sure the correct port is selected. • Is the printer in cooling mode? The message <code>Cooling</code> appears on the LCD. Wait until the message disappears and then try printing again. • Are there any unfinished print jobs? If you try to print while other users are printing large amounts of data, the printer is unable to accept your print job until the current print jobs are completed. If this occurs, send the print job again after the other jobs are completed.
I want to reset the printer/delete the data transferred from the computer.	See <i>Related Topics</i> .
I want to cancel the current print job.	Make sure that the printer is On, and then press the  (Power) button or  (Back) button.
Print head, motor, or battery is too hot.	<ul style="list-style-type: none"> • Head: If the print head becomes too hot, it may produce imaging on the paper in areas not intended to be printed. This condition is normal when printing documents with a lot of "black" content. The printer will stop and resume printing after the print head has cooled down. To avoid or delay this condition, print using a lighter density setting, reduce the amount of black space being printed (for example, remove background shading and colors in graphs and presentation documents), and make sure that the printer has adequate ventilation and is not located in an enclosed space. • Motor or battery: Do not use the printer continuously. If the printer is used continuously, the motor or battery will become too hot. In this case, the printer will stop and resume printing after the motor or battery has cooled down.
Transferring the program failed.	The system will recover if the program is transferred again. To resolve the issue, contact your Brother dealer or Brother customer service for assistance.

Related Information

- [Troubleshooting](#)

Related Topics:



- [Load the Roll](#)

-
- Device Settings of the Printer Setting Tool (Windows)
 - Maintenance
 - Reset the Printer
 - Change Printer Settings Using the Printer Setting Tool (Windows)
-

Network Problems

- >> Network Setup Problems
- >> Cannot Print over the Network / Printer Is Not Found on the Network Even after Successful Installation
- >> Security Software Problems
- >> Check the Operation of Network Devices

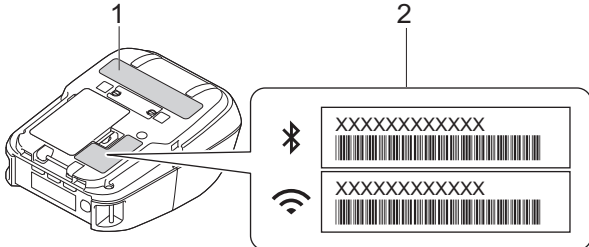
Network Setup Problems

Problem	Solution
You are using security software	<ul style="list-style-type: none"> • Confirm your settings in the printer driver installer dialog box. • Allow access when the security software alert message appears during the printer driver installation.
Your security settings (SSID/Network Key) are incorrect	<p>Make sure the network security settings are correct:</p> <ul style="list-style-type: none"> • See the instructions supplied with your Wi-Fi router/access point for information on how to find the security settings. • The default SSID (Network Name) may be your Wi-Fi router/access point's manufacturer name or model number. • Contact the manufacturer of your Wi-Fi router/access point or ask your Internet provider or network administrator.
The printer cannot connect to the mobile device using Wi-Fi or Bluetooth.	<ul style="list-style-type: none"> • Move the printer within about 3.3 feet (one meter) of the mobile device when you configure the Wi-Fi network settings. • Move the printer to an obstruction-free area. • If a wireless computer, Bluetooth-equipped device, microwave oven, digital cordless phone, or other device is near the printer or the Wi-Fi router/access point, move the device away from the printer or Wi-Fi router/access point.
The printer cannot print using Wi-Fi or Bluetooth.	
You are using MAC Address filtering.	<ul style="list-style-type: none"> • You can find the MAC address label on the base of the printer. You can also confirm the serial number by printing the printer information. <p> The serial number and MAC address labels are located on the base of the printer.</p>  <ol style="list-style-type: none"> 1. Serial number 2. MAC address <ul style="list-style-type: none"> • Set the Wi-Fi router/access point so that the MAC address of the printer is allowed for connections. For more information, see the instructions supplied with your Wi-Fi router/access point.
Your Wi-Fi access point/router is in stealth mode (not broadcasting the SSID)	<ul style="list-style-type: none"> • Enter the correct SSID name during the installation or when using Communication Settings in the Printer Setting Tool. • Check the SSID name in the instructions supplied with your Wi-Fi router/access point and set up your wireless network again.
The printer is not connected correctly to the network.	<p>Check the WLAN icon on the LCD.</p>  <p>: The printer is already connected to a wireless network. Check the wireless network information and connect your Wi-Fi router/access point correctly.</p>

Problem	Solution
	 : The printer is searching for the network. Make sure the Wi-Fi router/access point is available and wait a while. If the printer is still not connected, set up the printer's Wi-Fi connection again. No icon : The wireless network feature on your printer is off. Make sure that the printer is in the mode you want to use to connect.
I have checked and tried all of the above, but still cannot complete the wireless configuration.	Turn off the printer, and then turn it on again. Then try to configure the Wi-Fi settings again.

Cannot Print over the Network / Printer Is Not Found on the Network Even after Successful Installation

Problem	Solution
You are using security software	For more information, see <i>Related Topics</i> .
The printer is not assigned with an available IP address	<ul style="list-style-type: none"> Confirm the IP address and the Subnet Mask. Verify that both the IP addresses and Subnet Masks of your computer and the printer are correct and located on the same network. For more information on how to verify the IP address and the Subnet Mask, contact your network administrator. Confirm your IP address, Subnet Mask and other network settings in Communication Settings in the Printer Setting Tool. For more information, see <i>Related Topics</i>.
Your previous printing job failed.	If the failed printing job is still in your computer's print queue, delete it. For example, when using Windows 10: Click Start > Settings > Devices > Printers & scanners . Click your printer, and then click Open queue . Click Printer > Cancel All Documents
I have checked and tried all the above, but my printer does not print.	Uninstall the printer driver and software, and then reinstall them.

Security Software Problems

Problem	Solution
You did not choose to allow access when the security alert dialog box appeared during either the standard installation, BRAdmin Light installation, or when printing.	If you did not choose to accept the security alert dialog box, the firewall function of your security software may be rejecting access. Some security software may block access without showing a security alert dialog box. To allow access, see the instructions of your security software or contact the manufacturer.
Incorrect port numbers are being used for the Brother network features	The following port number is used for Brother network features: BRAdmin Light: Port number 161 / Protocol UDP For more information about how to open the port, see the instructions for the security software or contact its manufacturer.

Check the Operation of Network Devices

Problem	Solution
The printer and Wi-Fi router/access point are not turned on.	Make sure you have confirmed all the instructions listed in the Related Information topics.
I do not know my printer's network	Check Communication Settings in the Printer Setting Tool. For more information, see <i>Related Topics</i> .

Problem	Solution
settings, such as the IP address.	



Related Information

- [Troubleshooting](#)

Related Topics:

- [Change Printer Settings Using the Printer Setting Tool \(Windows\)](#)
-

Version Information

Problem	Solution
I do not know the current version of the printer's firmware.	You can confirm the version number of the firmware by printing the Printer Settings Report. For more information, see <i>Related Topics</i> .
I want to confirm whether I am using the latest version of the software.	Use the P-touch Update Software to confirm whether you have the latest version. For more information about the P-touch Update Software, see <i>Related Topics</i> .



Related Information

- [Troubleshooting](#)

Related Topics:

- [Device Settings of the Printer Setting Tool \(Windows\)](#)
- [Update P-touch Editor](#)

Reset the Printer







Reset the internal memory of your printer to clear all the saved label files, or if the printer is not operating correctly.

>> [Reset Settings Using the LCD](#)

>> [Reset Data Using the Printer Setting Tool](#)

Reset Settings Using the LCD

You can reset settings on the printer.

1. Press the  (Power) button to turn off the printer.
2. Press and hold the  (Power) button and the  (Feed) / **OK** button for about five seconds.
3. While holding the  (Power) button, press the  (Feed) / **OK** button as follows:
 - Two times: Reset the network settings
 - Four times: Reset the printer and user settings
 - Six times: Reset all settings to their factory settings
4. Release the  (Power) button.

Reset Data Using the Printer Setting Tool

You can use the Printer Setting Tool from a computer to:

- Delete the templates and databases
- Reset communication settings
- Reset all printer settings to the factory settings

Related Information

- [Troubleshooting](#)

Related Topics:

- [Change Printer Settings Using the Printer Setting Tool \(Windows\)](#)

Battery Charger (Optional) Problems

If you experience any problems that you cannot resolve, contact your Brother dealer or Brother customer service for assistance.

Problem	Solution
The Charge Indicator turned off, but the battery has not fully charged.	Charging stopped because the battery became too hot or too cold. Wait and try charging the battery later.
The Charge Indicator flashes in orange.	An error occurred during charging. <ul style="list-style-type: none">• Wipe the Charging Terminals of the charger and the battery with a dry cloth.• Replace the battery with a new one.• Wait and try charging the battery later.



Related Information

- [Troubleshooting](#)

Active Docking Station (Optional) Problems

If you experience any problems that you cannot resolve, contact your Brother dealer or Brother customer service for assistance.

Problem	Solution
The Charging LED turned off, but the battery has not fully charged.	Charging stopped because the battery became too hot or too cold. Wait and try charging the battery later.
The Charging LED flashes in red.	<ul style="list-style-type: none">• The Battery is not charged. Make sure the AC Adapter is plugged into the Active Docking Station.• Wipe the Docking Station Terminals of the Docking Station and the battery with a dry cloth.• Replace the battery with a new one.
The printer does not turn on when placed on the Docking Station.	<ul style="list-style-type: none">• Place the printer on the Docking Station correctly.• Make sure that the AC Adapter is correctly connected.• Reconnect the AC Adapter.
The printer does not print via LAN cable.	<ul style="list-style-type: none">• Place the printer on the Docking Station correctly.• Connect the LAN cable correctly.• Select the correct driver in the Devices and Printers. If the Docking Station is connected, your operating system will also display a copy of the printer driver icon (for example: Brother RJ-:****WB (Copy 1)) in the Devices and Printers. Make sure it is not selected.



Related Information

- [Troubleshooting](#)

Linerless Platen Upgrade (Optional) Problems

Problem	Solution
The print quality is poor.	<ul style="list-style-type: none">• Install the Linerless Platen Upgrade correctly.• Clean the print head.
The printer does not feed paper.	<ul style="list-style-type: none">• Install the Linerless Platen Upgrade correctly.• Set the roll correctly.• Check if a label or adhesive has stuck under the Roll Compartment Cover. If so, clean the inside of the cover.
The media is jammed.	<p>Check the following points. If the printer still remains jammed, replace the Linerless Platen Upgrade.</p> <ul style="list-style-type: none">• Install the Linerless Platen Upgrade correctly.• Wipe any adhesive residue left along the ejection path of the paper.• Clean the Roll Compartment and the Media Roll Holders.• The roll's adhesive may be too strong. Try using a different roll (with less adhesive).



Related Information

- [Troubleshooting](#)

Appendix

- [Specifications](#)
- [Software Development Kit](#)
- [Optional Accessories](#)
- [Product Dimensions](#)
- [Brother Help and Customer Support](#)
- [Compatible Operating Systems](#)
- [International ENERGY STAR® Qualification Statement \(USA and Canada Only\)](#)

Specifications

- >> [Printing](#)
- >> [Printer Size](#)
- >> [Interface](#)
- >> [Environment](#)
- >> [Power Supply](#)
- >> [Media Specification](#)
- >> [Compatible Operating Systems](#)

Printing

Printing Technology	Direct Thermal
Print Resolution	203 dpi
Print Speed (depending on the media used)	Maximum 5 ips (127 mm/s) ¹ Maximum 5 ips (127 mm/s) (When the Label Peeler is used.) Maximum 3 ips (76.2 mm/s) (When the Linerless Platen Upgrade is used.)
Maximum Print Width	2.8" (72 mm)
Maximum Print Length	118.11" (3000 mm)
Minimum Print Length	0.5" (12.7 mm)

¹ Using Brother's print test data (10% coverage, 2.99" x 1.14" (76 mm x 29 mm)) at 73.4°F (23°C) when performing continuous printing using a USB connection with a new, fully-charged battery.

Printer Size

Weight (including the battery)	Approximately 1.78 lb (807 g)
Dimensions	Approximately 4.6" (W) x 3" (H) x 7.1" (D) (117 mm (W) x 77 mm (H) x 180 mm (D))

Interface

USB	USB Ver.2.0 (Full Speed) (Type C)
Bluetooth	Bluetooth Ver.5.0 SPP, OPP, HCRP (Bluetooth Classic), GATT (Bluetooth Low Energy) Supported protocol: iAP
Ethernet	10 or 100 Mbps Ethernet (Enabled automatically when the printer is placed on the Active Docking Station)
Wireless LAN (5 GHz)	IEEE 802.11 a/n, 802.11i, 802.11r, WPS2.0 (Infrastructure Mode)
Wireless LAN (2.4 GHz)	IEEE 802.11 b/g/n, 802.11i, 802.11r, WPS2.0 (Infrastructure Mode) IEEE 802.11 g/n, 802.11d, 802.11i (Wireless Direct mode)
Protocol (IPv4)	ARP, RARP, BOOTP, DHCP, APIPA(Auto IP), WINS/NetBIOS name resolution, DNS Resolver, mDNS, LLMNR responder LPR, LPD, Custom Raw Port/Port9100, IPP/IPPS, FTP Client and Server, SNMPv1/v2c/v3, HTTP/HTTPS Client and Server, TFTP Server, ICMP, Web Services (Print), SNMP Client
Protocol (IPv6)	NDP, RA, DNS Resolver, mDNS, LLMNR responder, LPR, LPD, Custom Raw Port/Port9100, IPP/IPPS, FTP Client and Server, SNMPv1/v2c/v3, HTTP/HTTPS Client and Server, TFTP Server, ICMP, Web Services (Print), SNMP Client
Network Security (Wired)	SSL/TLS1.0/1.1/1.2 (HTTPS, IPPS) SNMPv3, 802.1x (EAP-MD5, EAP-FAST, PEAP, EAP-TLS, EAP-TTLS)

Network Security (Wireless)	SSL/TLS1.0/1.1/1.2 (HTTPS, IPPS) SNMPv3, 802.1x (EAP-FAST, PEAP, EAP-TLS, EAP-TTLS)
Wireless Network Security	WEP 64/128 bit, WPA-PSK (TKIP/AES), WPA2-PSK (AES), WPA3-SAE (AES)
Wireless Certification	Wi-Fi Certification Mark License (WPA™/WPA2™/WPA3™ - Enterprise, Personal), Wi-Fi Protected Setup™ (WPS) Identifier Mark License

Environment

Operating Temperature	<p>Operation:</p> <p>Battery: From -4°F to 131°F (From -20°C to 55°C)</p> <p>AC Adapter (Optional): From 14°F to 104°F (From -10°C to 40°C)</p> <p>Car Adapter (Optional): From 14°F to 122°F (From -10°C to 50°C)</p> <p>From -4°F to 131°F (From -20°C to 55°C) (When no accessories are used.) (Recommended Temperature is from 32°F to 104°F (from 0°C to 40°C))</p> <p>From 14°F to 95°F (From -10°C to 35°C) (When the Label Peeler is used.)</p> <p>From 50°F to 86°F (From 10°C to 30°C) (When the Linerless Platen Upgrade is used.)</p> <p>Charging:</p> <p>From 32°F to 104°F (From 0°C to 40°C)(Recommended Temperature is from 41°F to 95°F (from 5°C to 35°C))</p> <p>If the internal temperature of the battery is out of this range, charging may stop.</p>
Operating Humidity	<p>From 10% to 90% (without condensation)</p> <p>50% (When the Label Peeler/Linerless Platen Upgrade is used.)</p>

Power Supply

Battery	Rechargeable Li-ion battery: 7.2 V
AC Adapter (Optional)	AC Adapter (15 V)
Car Adapter (Optional)	Car Adapter or Wired type (12 V (DC))
Maximum number of printed labels ¹	15,000
Charging time	About 3 hours

¹ Using Brother's print test data (10% coverage, 2.99" × 1.14" (76 mm × 29 mm)) at 73.4°F (23°C) when performing continuous printing using a USB connection with a new, fully-charged battery.

Media Specification

The media material may affect the print quality.

In order to achieve optimum print results, we recommend using genuine Brother media.

Media Type	Receipt, Gap/Black mark Label, Tag, Linerless (Optional)
Media Width	From 1" to 3.14" (From 25.4 mm to 80 mm)
Thickness	<p>Receipt: From 2.2 mil to 3.5 mil (From 0.058 mm to 0.090 mm)</p> <p>Tag: From 3.5 mil to 5.5 mil (From 0.090 mm to 0.140 mm)</p> <p>Label: From 3.1 mil to 6.6 mil (From 0.080 mm to 0.170 mm)</p>
Roll Outside Diameter (maximum)	2.6" (66 mm)
Media Roll Holder Core Diameter	<p>Standard (Black): 0.5"- 0.51" (12.7 mm - 13 mm) or 0.75" (19 mm) (Default: 0.75" (19 mm))</p> <p>In-box (Light Gray): 1.375" (34.9 mm)</p> <p>Optional (Gray): 1" (25.4 mm)</p> <p>Optional (Black): 0.48"- 0.51" (12 mm - 13 mm)</p>

Media Sensor	Transmissive, Reflective
---------------------	--------------------------

Compatible Operating Systems

For the latest list of compatible software, visit support.brother.com.



Related Information

- [Appendix](#)

Related Topics:

- [Load the Roll](#)
-

Software Development Kit

Software Development Kit (SDK) is available from the Brother Developer Center (<https://support.brother.com/g/s/es/dev/en/index.html>).

The b-PAC SDK and the SDKs for mobile devices (Android™, iPhone, and iPad) can also be downloaded. (The SDKs available are subject to change without notice.)



Related Information

- [Appendix](#)

Optional Accessories

- [Battery Charger \(Optional: PA-BC-003\)](#)
- [Label Peeler \(Optional: PA-LP-007\)](#)
- [Linerless Platen Upgrade \(Optional: PA-LPR-004\)](#)
- [Single Active Docking Station \(Optional: PA-CR-005\)](#)
- [4-bay Active Docking Station \(Optional:PA-4CR-003\)](#)

Battery Charger (Optional: PA-BC-003)

- [Battery Charger Overview](#)
- [Charge the Battery Using the Battery Charger](#)
- [Mount the Battery Charger on the Wall](#)
- [Connect Multiple Battery Chargers Together](#)

Battery Charger Overview

Parts Description

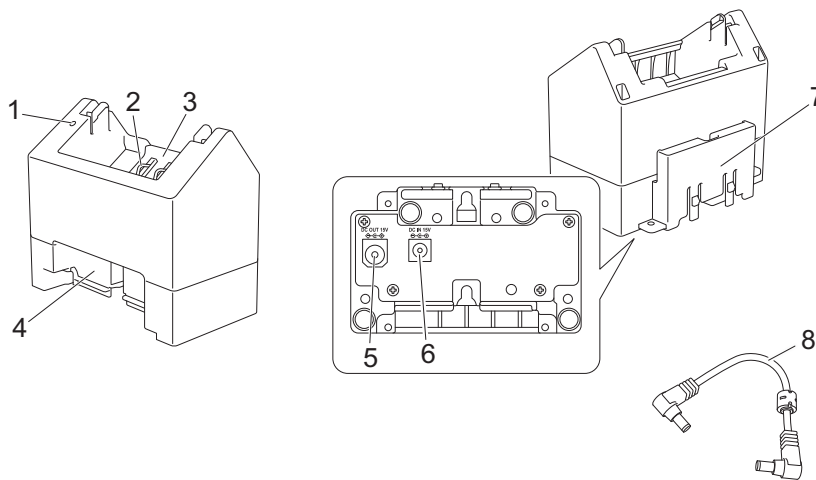

1. Charge Indicator
2. Battery Charging Terminals
3. Battery Compartment
4. Locking Expansion Slot
5. DC Connector OUT
6. DC Connector IN
7. Locking Expansion Hook
8. DC Cord

Specifications

Charge time	Approximately 4 hours ¹
Charge temperature	32°F to 104°F/0°C to 40°C (Recommended: 41°F to 95°F/5°C to 35°C)
Operating humidity	10% to 90% (No condensation)

¹ Varies depending on the operating environment and the condition of the battery.

✓ Related Information

- [Battery Charger \(Optional: PA-BC-003\)](#)

Charge the Battery Using the Battery Charger

To charge the rechargeable Li-ion battery, use the Battery Charger (PA-BC-003) together with the AC Adapter (PA-AD-600A, sold separately).

The Battery Charger cannot charge the battery alone.

1. Connect the AC Adapter to the Battery Charger's DC Connector IN.
2. Connect the AC power cord to the AC Adapter.

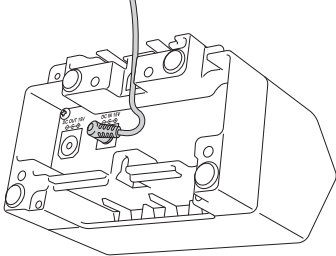

Insert the AC Adapter cord through the opening in the Battery Charger as shown in the illustration. Make sure you do not pinch the cord.

3. Connect the AC power cord to a nearby AC power outlet.
4. Align the Battery Charging Terminals of the charger and the battery, and then insert the battery.
The Charge Indicator lights in orange when the battery is charging.
5. The Charge Indicator will turn off when charging is complete. Remove the battery.

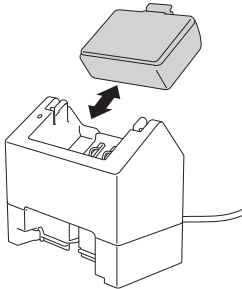

Related Information

- [Battery Charger \(Optional: PA-BC-003\)](#)

Mount the Battery Charger on the Wall

Use two screws to mount the Battery Charger to a wall.

- Install the screws vertically with the spacing shown below.

Ensure the screws are correctly secured with wall anchors or studs. The battery compartment must face upward (as shown) to hold the battery in place.

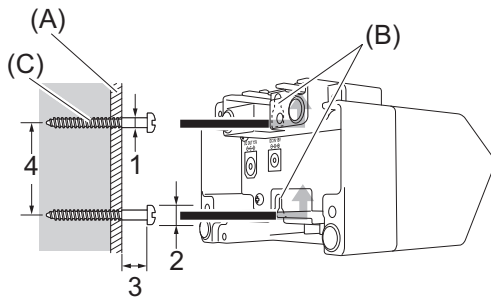

1. Dia. 0.12" - 0.18" (3 mm - 4.5 mm)
2. Dia. 0.33" (8.5 mm) or less
3. 0.48" (12.2 mm) or more
4. 1.75" - 1.87" (44.5 mm - 47.5 mm)

- (A) Wall material
(B) Wall-mount slots
(C) Screw

Use the insert nuts on the base of the Battery Charger to fasten the screws to the wall.

- Use the following types of screws.
 - M2.6 Pitch 0.45 screws
 - Screws that are between 0.14" (3.5 mm) and 0.28" (7 mm) longer than the thickness of the board (when attaching to a vertical board).



- When attaching to a vertical board, the method of installation is the same as wall mounting.
- Be sure not to pinch the cables between the base of the Battery Charger and the board.

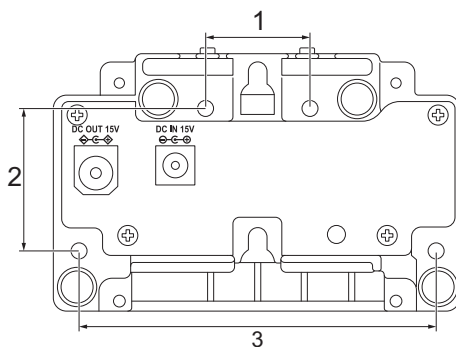

1. 1.09" (27.7 mm)
2. 1.5" (38 mm)
3. 3.74" (95 mm)

✓ Related Information

- [Battery Charger \(Optional: PA-BC-003\)](#)

Connect Multiple Battery Chargers Together

Up to four battery chargers can be connected in-line together.

>> [Connect the Battery Chargers](#)

>> [Disconnect the Battery Chargers](#)

Connect the Battery Chargers

1. Insert the Locking Expansion Hook of the first Battery Charger into the Locking Expansion Slot of the second Battery Charger until it locks into place.

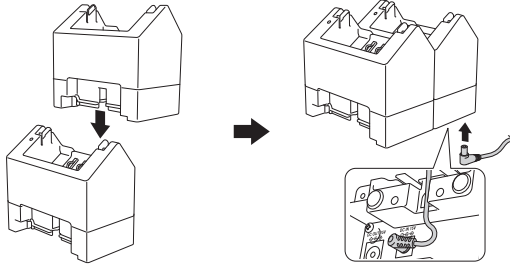

2. Connect the AC Adapter to the first Battery Charger.
3. Connect one end of the included DC cord to the DC Connector OUT of the first Battery Charger.

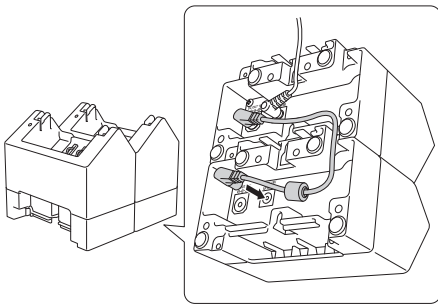

4. Connect the other end of the DC cord to the DC Connector IN of the second Battery Charger.



- Connect the AC Adapter and DC cord through the opening in the Battery Charger as shown in the illustration.

Make sure you do not pinch the cords when connecting the Battery Chargers.

- When connecting the Battery Chargers, we recommend using self-tapping screws (M2.6 x 0.24" (6 mm)) (not included) to firmly secure the Battery Chargers to one another.

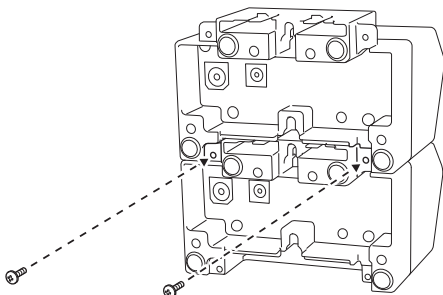

Disconnect the Battery Chargers

1. Disconnect the DC cord and the AC Adapter from the Battery Chargers.
2. Push the tab on the Locking Expansion Hook to release the lock.
3. Disconnect the Battery Chargers.

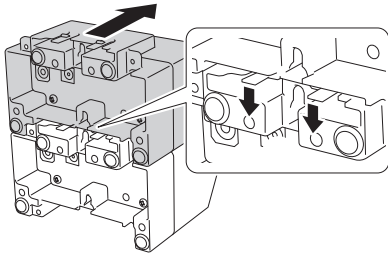

✓ Related Information

- [Battery Charger \(Optional: PA-BC-003\)](#)

Label Peeler (Optional: PA-LP-007)

- [Install the Label Peeler](#)
- [Enable the Label Peeler Function](#)

Install the Label Peeler

This printer is compatible with the Label Peeler (PA-LP-007).

Parts Description

Label Peeler Assembly Screws (2 each)

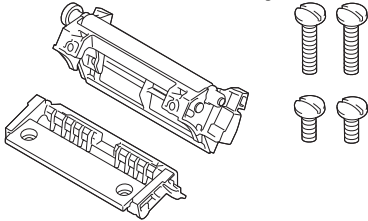

1. Push the Roll Cover Release Lever to open the Roll Compartment Cover.

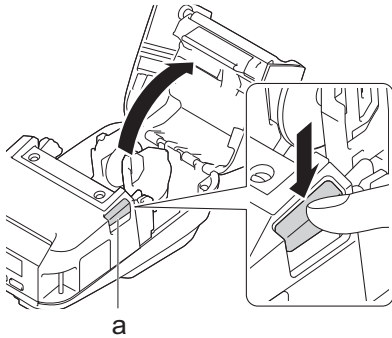

a. Roll Cover Release Lever

2. Remove the standard platen and holder unit by removing the four screws shown in the illustration.

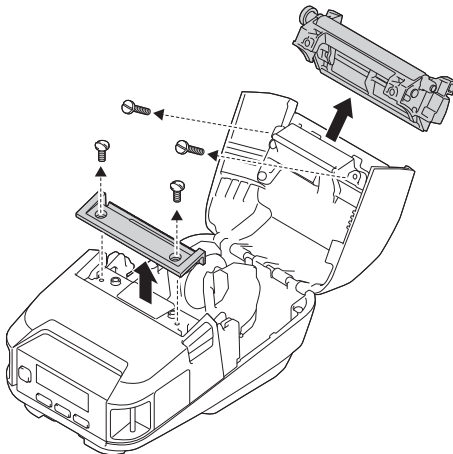

CAUTION

- Do not touch the blade when removing the standard platen.
- Do not touch the tear bar when removing the holder unit.



Recommended tightening torque: 4.87 ± 0.434 in·lbs (0.55 ± 0.049 N·m).

3. Install the platen and holder unit, and fasten them using the four screws supplied with the Label Peeler.

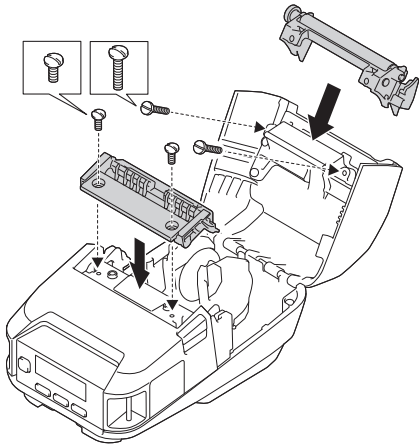

The upper tear bar and lower tear bar cannot be used when the Label Peeler is installed.

4. Peel off a few labels. Then, set the Roll so that the next label does not cover the Media Sensor area.

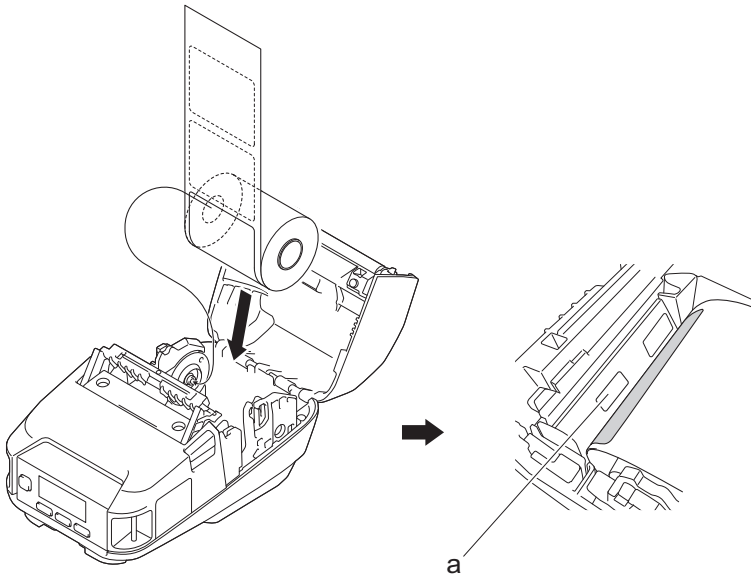

a. Media sensor

5. Close the Roll Compartment Cover.
6. Lightly pull on the paper in the Paper Exit Slot to remove any slack in the roll.

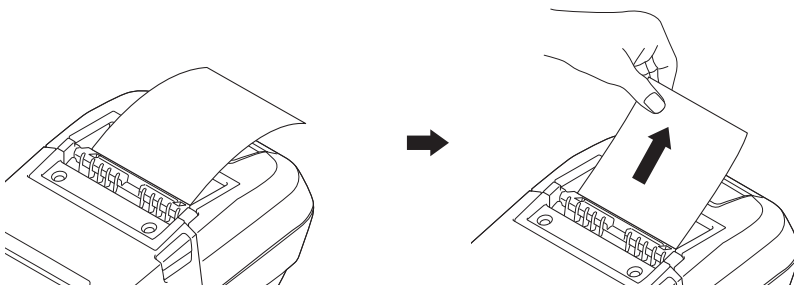

IMPORTANT

- Before using the Label Peeler, specify the following settings:
 - Set **Exit Position** to **Peeler** in the **Basic** tab of the Printer Setting Tool.
 - Select the **Use Peeler Function** check box on the **Basic** tab of the printer driver properties. For more information, see *Related Topics*.
- When not using the Label Peeler, specify the following settings:
 - Set **Exit Position** to [Tear Bar] in the **Basic** tab of the Printer Setting Tool.
 - Clear the **Use Peeler Function** check box on the **Basic** tab of the printer driver properties.

7. Set **Exit Position** to **Peeler** in the **Basic** tab of the Printer Setting Tool.

NOTE

- When **Peeler** is set to **Exit Position**, [Tear Bar] in [Settings] and [Auto Detect] in [Media] cannot be selected on the printer's LCD.
- For best performance, make sure the paper's head margin is at least 0.12" (3 mm).
- When using the Label Peeler, paper dust may stick to the print head. Clean the print head regularly. For more information, see *Related Topics*:
- Use the latest firmware when printing with the Label Peeler.



Related Information

- [Label Peeler \(Optional: PA-LP-007\)](#)

Related Topics:

- [Maintenance](#)
 - [Enable the Label Peeler Function](#)
-

Enable the Label Peeler Function

When printing using the printer driver, enable the **Use Peeler Function** setting.

1. Do one of the following:
 - **Windows 10/Windows Server 2016/Windows Server 2019:**
Click **Start > Settings > Devices > Printers & scanners**. Click the printer you want to set up, and then click **Open queue**. Click **Printer > Printing Preferences**.
 - **Windows 8.1/Windows Server 2012/Windows Server 2012 R2:**
Click **Control Panel** in the **Apps** screen. Click **Hardware and Sound > Devices and Printers**. Right-click the printer you want to set up, and then click the **Printing preferences** menu.
 - **Windows 7:**
Click **Start > Devices and Printers**. Right-click the printer you want to set up, and then click the **Printing preferences** menu.
2. Select the **Use Peeler Function** check box.
3. Click **OK**.



Related Information

- [Label Peeler \(Optional: PA-LP-007\)](#)

Linerless Platen Upgrade (Optional: PA-LPR-004)

- [Install the Linerless Platen Upgrade](#)

Install the Linerless Platen Upgrade

This printer is compatible with linerless media.

Parts Description

Linerless Platen Assembly Screws (2)

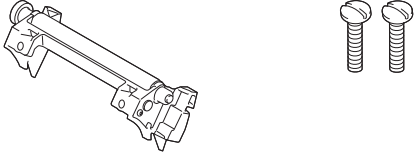

1. Push the Roll Cover Release Lever to open the Roll Compartment Cover.

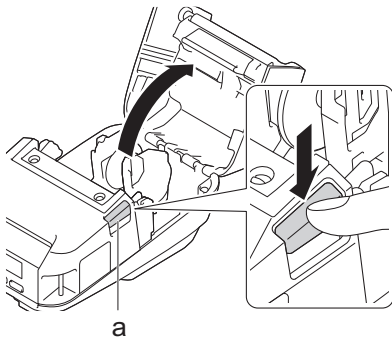

a. Roll Cover Release Lever

2. Remove the standard platen by removing the two screws shown in the illustration.

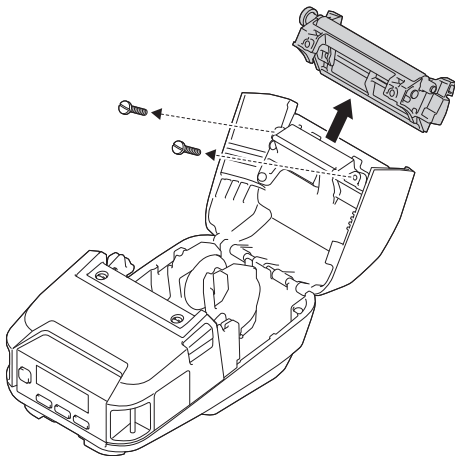

CAUTION

Do not touch the blade when removing the standard platen.



Recommended tightening torque: 4.87 ± 0.434 in·lbs (0.55 ± 0.049 N·m).

3. Install the Linerless Platen Assembly, and fasten it using the two screws included in the Linerless Platen Upgrade.

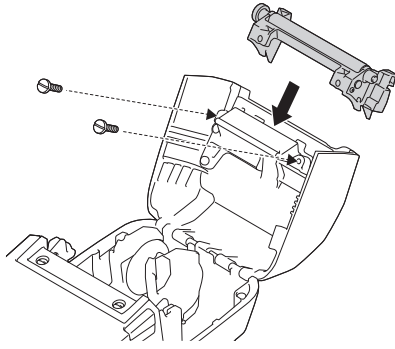

The lower tear bar cannot be used when the Linerless Platen Upgrade is installed.

4. Set **Linerless** to **On** in the **Advanced** tab of the Printer Setting Tool.

NOTE

- When **Linerless** is set to **On**, [Tear Bar] in [Settings] and [Auto Detect] in [Media] cannot be selected on the printer's LCD.
- For best performance, make sure the paper's head margin is at least 0.47" (12 mm).
- When using the Linerless Platen Upgrade, paper dust may stick to the print head. Clean the print head regularly. For more information, see *Related Topics*:
- Use the latest firmware when printing with the Linerless Platen Upgrade.



Related Information

- [Linerless Platen Upgrade \(Optional: PA-LPR-004\)](#)

Related Topics:

- [Maintenance](#)
- [Linerless Platen Upgrade \(Optional\) Problems](#)

Single Active Docking Station (Optional: PA-CR-005)

- [Single Active Docking Station Overview](#)
- [Charge the Battery Using the Single Active Docking Station](#)
- [Connect the Printer to a Wired LAN Network via Single Active Docking Station](#)
- [Mount the Single Active Docking Station on the Wall](#)

Single Active Docking Station Overview

Parts Description

Single Active Docking Station

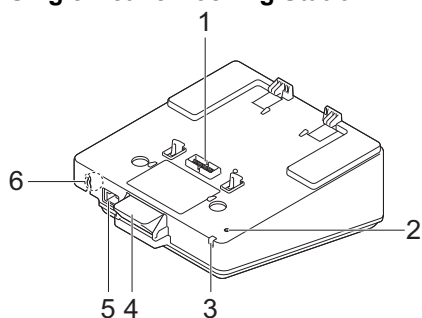

1. Docking Station Terminals
2. Ethernet (LAN) LED
3. Charging LED
4. Eject Button
5. Ethernet (LAN) Port
6. DC Connector

Specifications

Charging time	About 3 hours ¹
Charging temperature	From 41°F to 95°F (From 5°C to 35°C)
Operating temperature	From 32°F to 104°F (From 0°C to 40°C)
Operating humidity	From 10% to 90% (without condensation)

¹ Varies depending on the operating environment and the condition of the battery.

NOTE

When the printer is placed on the Docking Station, we recommend using the **After one page of data is received** setting in the **Other** tab of the printer driver properties before printing.



Related Information

- [Single Active Docking Station \(Optional: PA-CR-005\)](#)

Related Topics:

- [Active Docking Station \(Optional\) Problems](#)

Charge the Battery Using the Single Active Docking Station

The Single Active Docking Station (PA-CR-005) cannot recharge the printer's battery without being connected to an AC power outlet using the AC Adapter (PA-AD-600A).

>> [Charge the Battery](#)

>> [Remove the Printer from the Docking Station](#)

>> [Lock the Eject Button](#)

Charge the Battery

1. Connect the AC Adapter to the Docking Station's DC Connector.

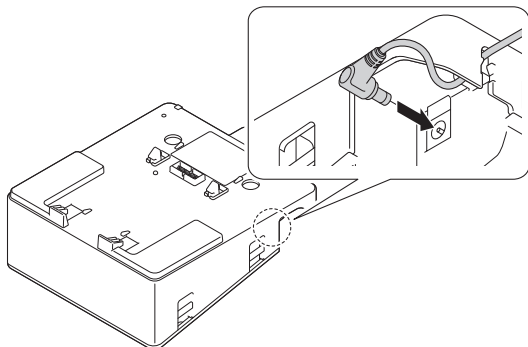

2. Connect the AC power cord to the AC Adapter.
3. Connect the AC power cord to a nearby AC power outlet.
4. Align the Docking Station Terminals of the Docking Station and the printer.

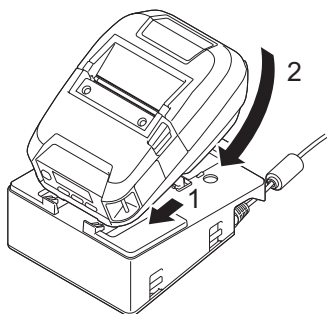

5. Press the printer down and onto the Docking Station until the latches lock it firmly in place.
The printer's LED Indicator lights in orange when charging.

- The printer's LED Indicator will turn off when charging is complete.

Remove the Printer from the Docking Station

- Push the Eject Button on the back of the Docking Station, lift the printer, and then remove it from the Docking Station.

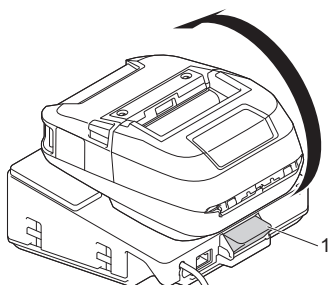

1. Eject Button

Lock the Eject Button

- Insert a cotter pin (or similar) through the hole as illustrated below.



Use a Low Carbon Steel Extended Prong Retaining Cotter Pin (not included): Length: 1.97" (50 mm), Pin Diameter: 0.08" (2 mm)

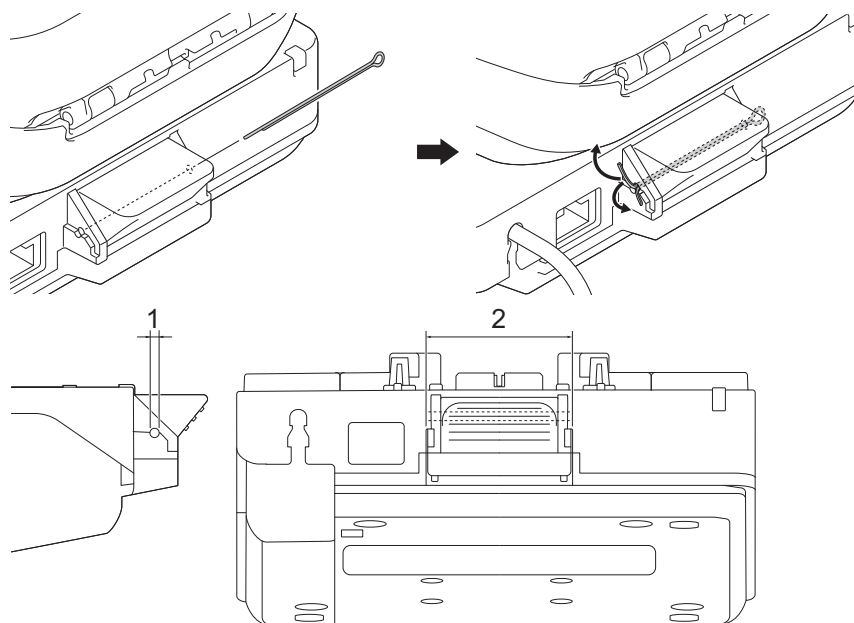

1. Diameter: 0.09" (2.3 mm)
2. Length: 1.62" (41.2 mm)



To purchase the Cotter Pin, contact your local Brother dealer.



Related Information

- [Single Active Docking Station \(Optional: PA-CR-005\)](#)

Connect the Printer to a Wired LAN Network via Single Active Docking Station

Use an Ethernet (LAN) connection to configure your printer and upgrade its firmware.

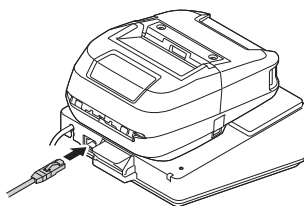

NOTE

Make sure that the Ethernet (LAN) cable is fully inserted in the Ethernet (LAN) Port.

LED Indicators

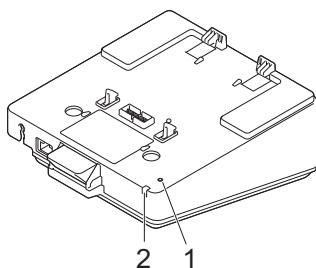

1. Ethernet (LAN) LED

LED Indicator	Status
	Ethernet (LAN) not connected
	<ul style="list-style-type: none"> Ethernet (LAN) connected Receiving or sending data via Ethernet (LAN)

NOTE

The Ethernet (LAN) LED does not light up unless the printer is placed on the Single Active Docking Station.

2. Status LED

LED Indicator	Status
	The printer is placed on the Single Active Docking Station and the battery is fully charged.
	The printer is charging on the Single Active Docking Station.

Interface compatibility

Use the [WLAN] and [Wired LAN] menus to select WLAN, Wired LAN, or no connection when the printer is on the Single Active Docking Station.

Cradle LAN Setting	WLAN Setting	Connection type when using the Single Active Docking Station
On	On	WLAN →Wired LAN ¹
On	Off	Wired LAN

Cradle LAN Setting	WLAN Setting	Connection type when using the Single Active Docking Station
Off	On	WLAN
Off	Off	No connection enabled



Related Information

- [Single Active Docking Station \(Optional: PA-CR-005\)](#)
-

¹ Wireless Direct function is not affected.

Mount the Single Active Docking Station on the Wall

1. Drill four holes in a commercially available board according to the spacing of the screw holes of the Single Active Docking Station.

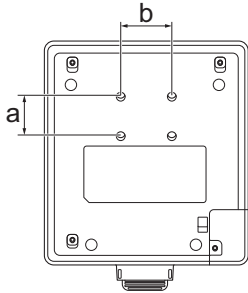

- a. Height: 1.18" (30 mm)
- b. Width: 1.5" (38.1 mm)

2. Affix the Docking Station to the board using four screws, as shown in the illustration.

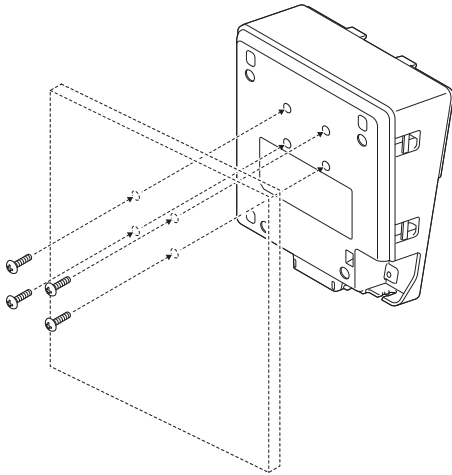

- Make sure you install the Docking Station in the correct direction so that the printer will not fall.
- Use M5 size screws.

3. Lean the board against the wall or secure the board to the wall.



Related Information

- [Single Active Docking Station \(Optional: PA-CR-005\)](#)

4-bay Active Docking Station (Optional:PA-4CR-003)

- [4-bay Active Docking Station Overview](#)
- [Charge the Battery Using the 4-bay Active Docking Station](#)
- [Connect the Printer to a Wired LAN Network via 4-bay Active Docking Station](#)
- [Mount the 4-bay Active Docking Station on the Wall](#)

4-bay Active Docking Station Overview

Parts Description

4-bay Active Docking Station

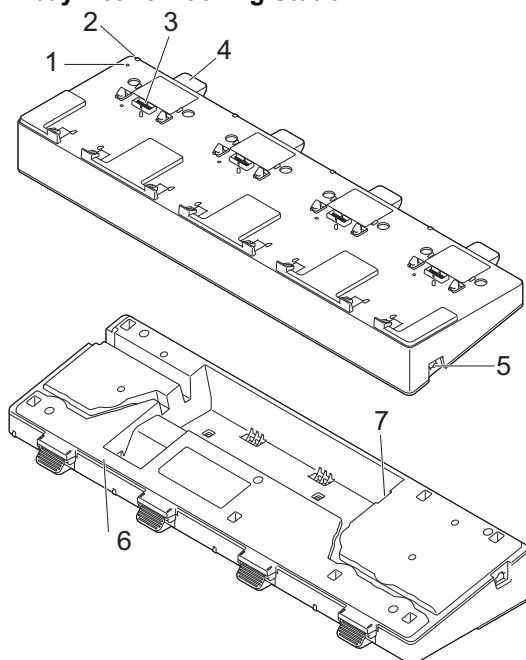

1. Ethernet (LAN) LED
2. Charging LED
3. Docking Station Terminals
4. Eject Button
5. Ethernet (LAN) Port 1
For connecting to a wired network.
6. DC Connector
7. Ethernet (LAN) Port 2
For connecting multiple 4-bay Active Docking Stations to each other.

Specifications

Charging time	About 3 hours ¹
Charging temperature	From 41°F to 95°F (From 5°C to 35°C)
Operating temperature	From 32°F to 104°F (From 0°C to 40°C)
Operating humidity	From 10% to 90% (without condensation)

¹ Varies depending on the operating environment and the condition of the battery.

NOTE

When the printer is placed on the Docking Station, we recommend using the **After one page of data is received** setting in the **Other** tab of the printer driver properties before printing.

✓ Related Information

- [4-bay Active Docking Station \(Optional:PA-4CR-003\)](#)

Related Topics:

- [Active Docking Station \(Optional\) Problems](#)
-

Charge the Battery Using the 4-bay Active Docking Station

The 4-bay Active Docking Station cannot recharge the printer's battery without being connected to an AC power outlet using the AC adapter (PA-AD-600A).

>> [Charge the Battery](#)

>> [Remove the Printer from the Docking Station](#)

Charge the Battery

1. Connect the AC Adapter to the Docking Station's DC Connector.

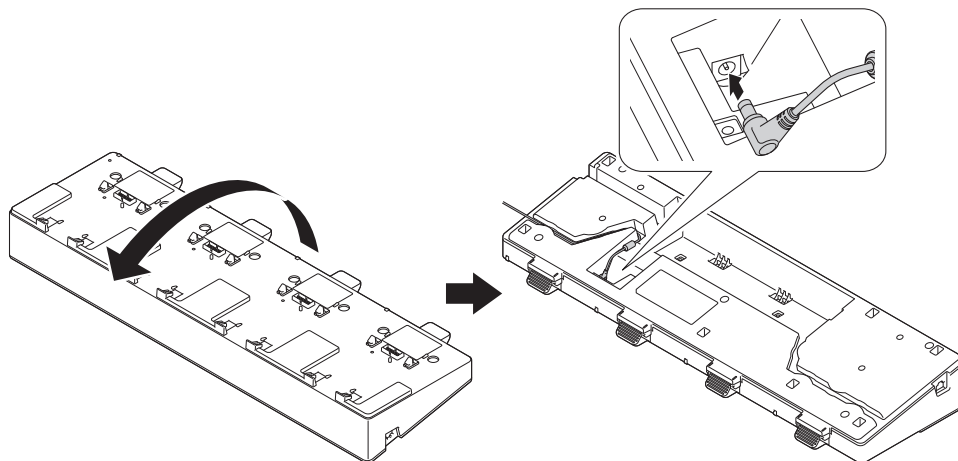

2. Connect the AC power cord to the AC Adapter.
3. Connect the AC power cord to a nearby AC power outlet.
4. Align the Docking Station Terminals of the Docking Station and the printer.

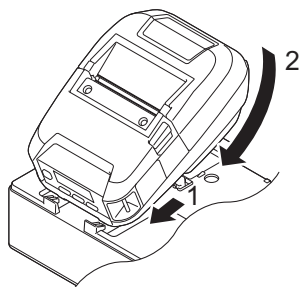

5. Press the printer down and onto the Docking Station until the latches lock it firmly in place.

The printer's LED Indicator lights in orange when charging.

The printer's LED Indicator will turn off when charging is complete.

Remove the Printer from the Docking Station

- Push the Eject Button on the back of the Docking Station, lift the printer, and then remove it from the Docking Station.

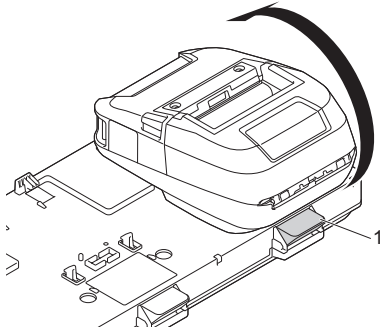

1. Eject Button



Related Information

- [4-bay Active Docking Station \(Optional:PA-4CR-003\)](#)

Connect the Printer to a Wired LAN Network via 4-bay Active Docking Station

Use an Ethernet (LAN) connection to configure your printer and upgrade its firmware.

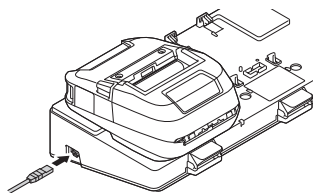

NOTE

Make sure that the Ethernet (LAN) cable is fully inserted in the Ethernet (LAN) Port.

LED Indicators

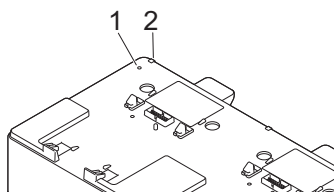

1. Ethernet (LAN) LED

LED Indicator	Status
	Ethernet (LAN) not connected
	Ethernet (LAN) connected
	Receiving or sending data via Ethernet (LAN)

2. Status LED

LED Indicator	Status
	The printer is placed on the 4-bay Active Docking Station and the battery is fully charged.
	The printer is charging on the 4-bay Active Docking Station.

Interface Compatibility

Use the [WLAN] and [Wired LAN] menus to select WLAN, Wired LAN, or no connection when the printer is on the 4-bay Active Docking Station.

Cradle LAN Setting	WLAN Setting	Connection type when using the 4-bay Active Docking Station
On	On	WLAN →Wired LAN ¹
On	Off	No connection enabled →Wired LAN
Off	On	WLAN
Off	Off	No connection enabled

¹ Wireless Direct function is not affected.



Related Information

- [4-bay Active Docking Station \(Optional:PA-4CR-003\)](#)

Mount the 4-bay Active Docking Station on the Wall

1. Drill four holes in a commercially available board according to the spacing of the screw holes of the 4-bay Active Docking Station.

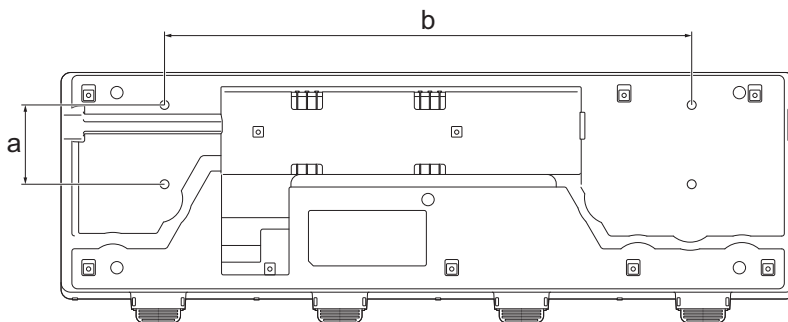

- a. Height: 2.4" (61 mm)
- b. Width: 16" (406.4 mm)

2. Affix the Docking Station to the board using four screws, as shown in the illustration.

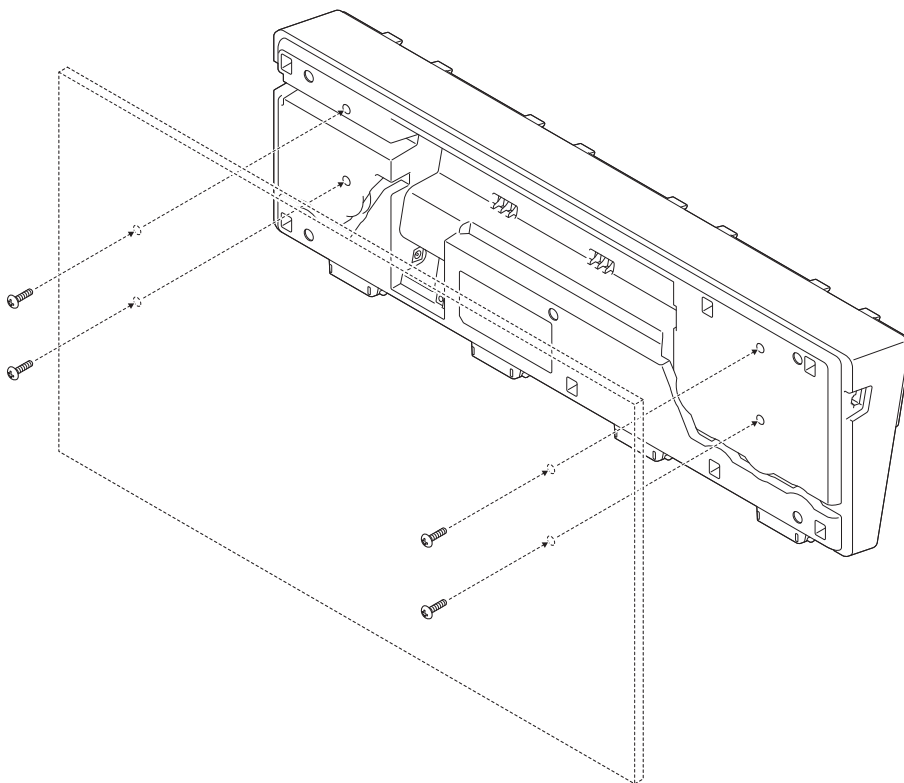

- Make sure you install the Docking Station in the correct direction so that the printer will not fall.
- Use M5 size screws.

3. Lean the board against the wall or secure the board to the wall.



Related Information

- [4-bay Active Docking Station \(Optional:PA-4CR-003\)](#)

Product Dimensions



All measured values are in millimeters.

Printer

Front view / Back view

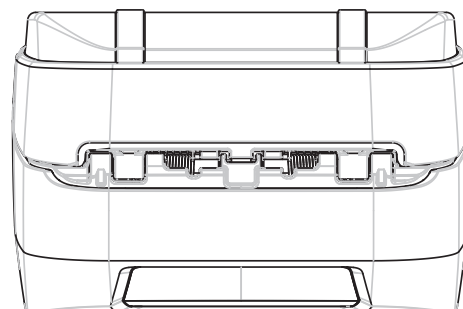
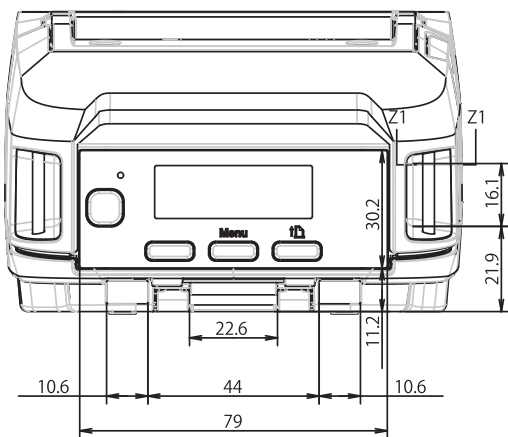

Top view / Bottom view

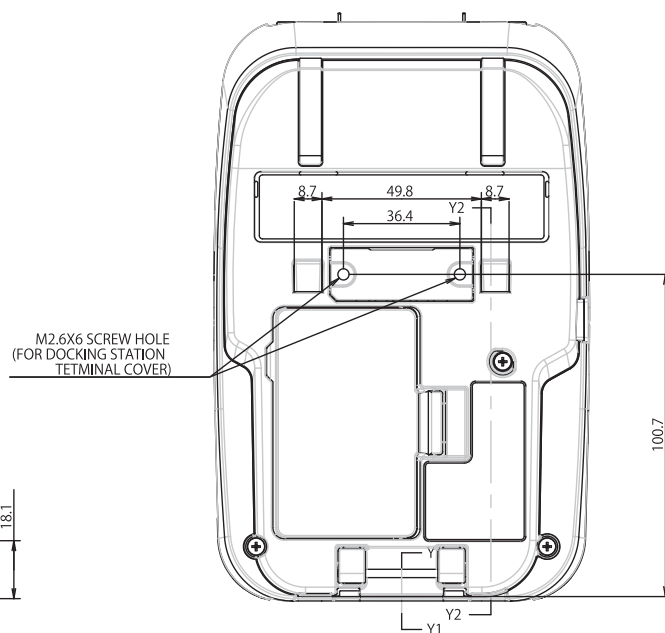
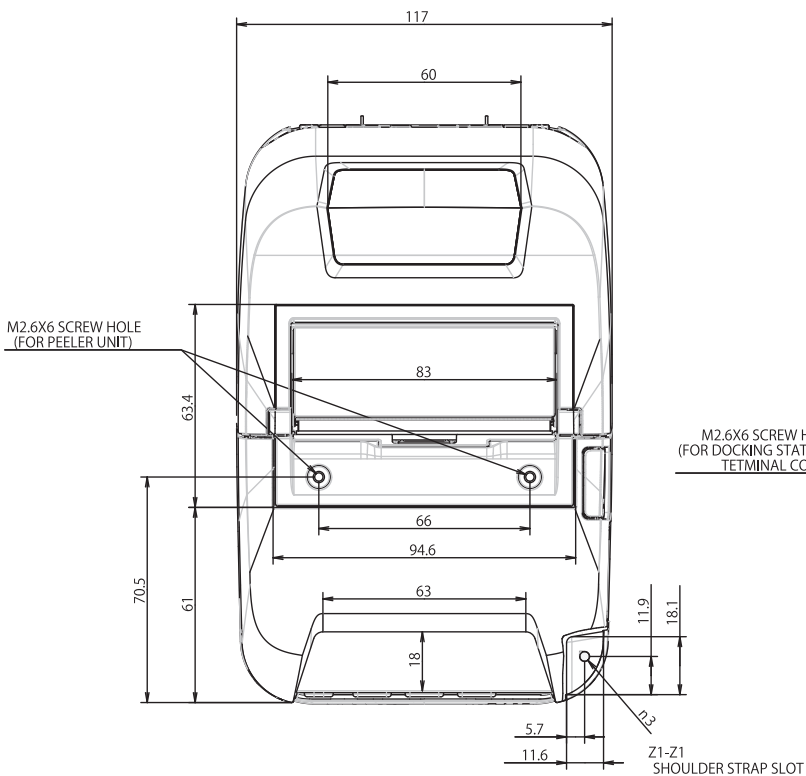

Side view

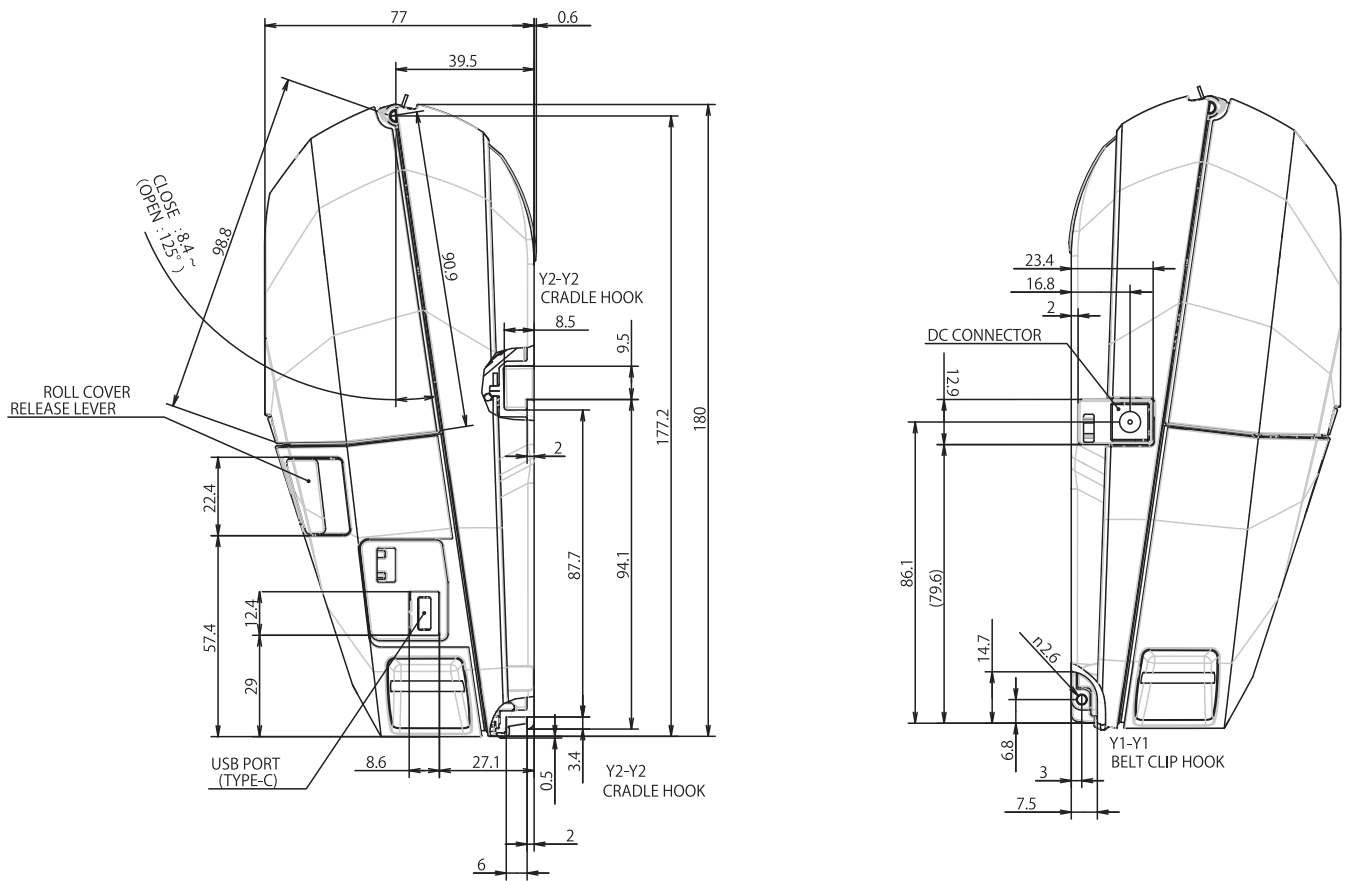

Battery Charger

Front view / Back view

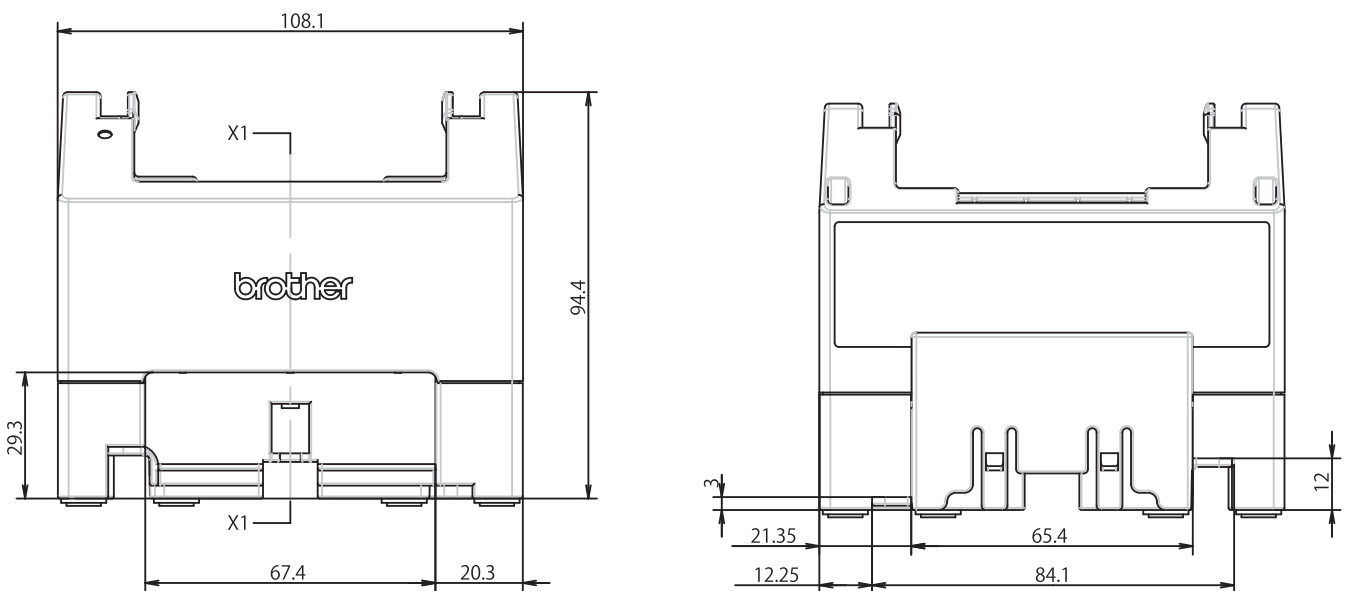

Top view / Bottom view

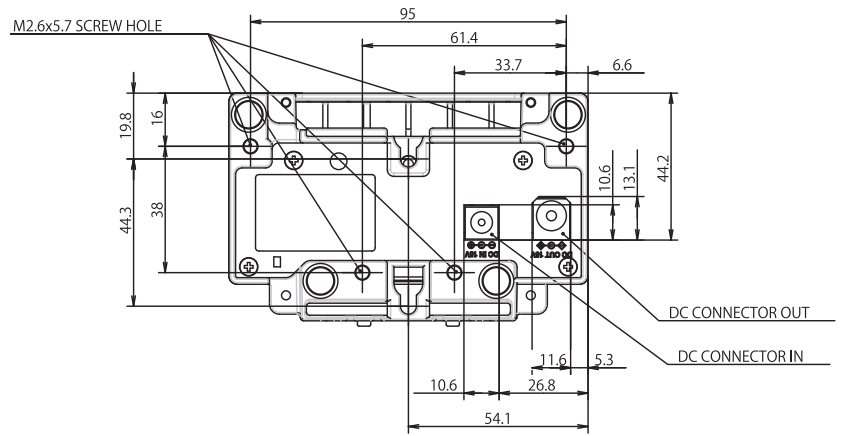
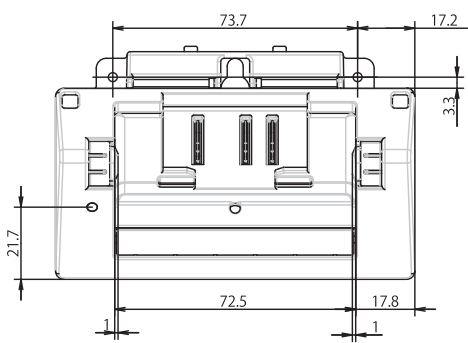

Side view

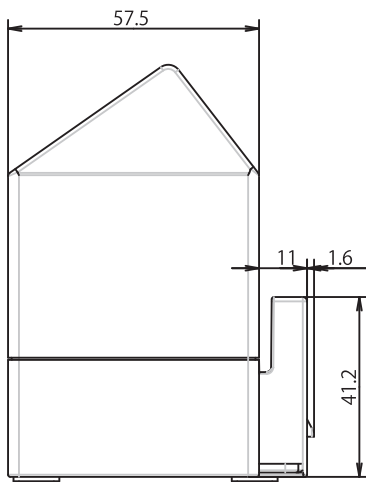

Cross section

X1-X1

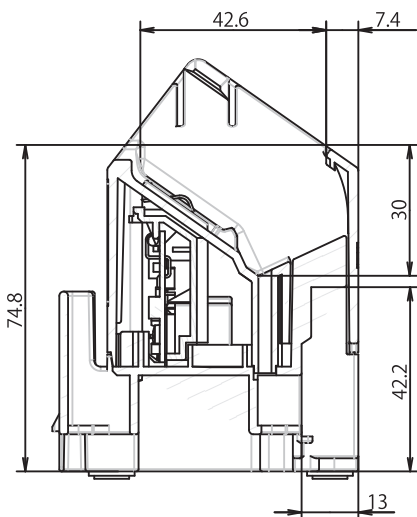

Single Active Docking Station

Front view / Back view

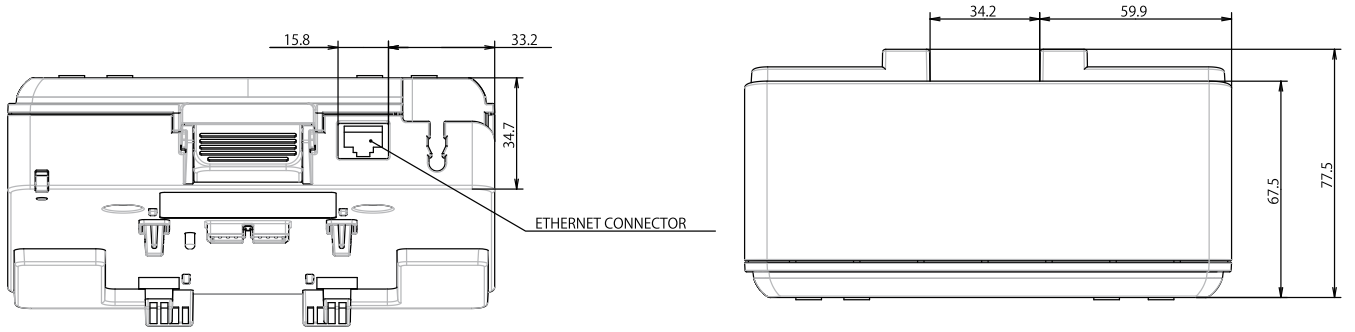

Top view / Bottom view

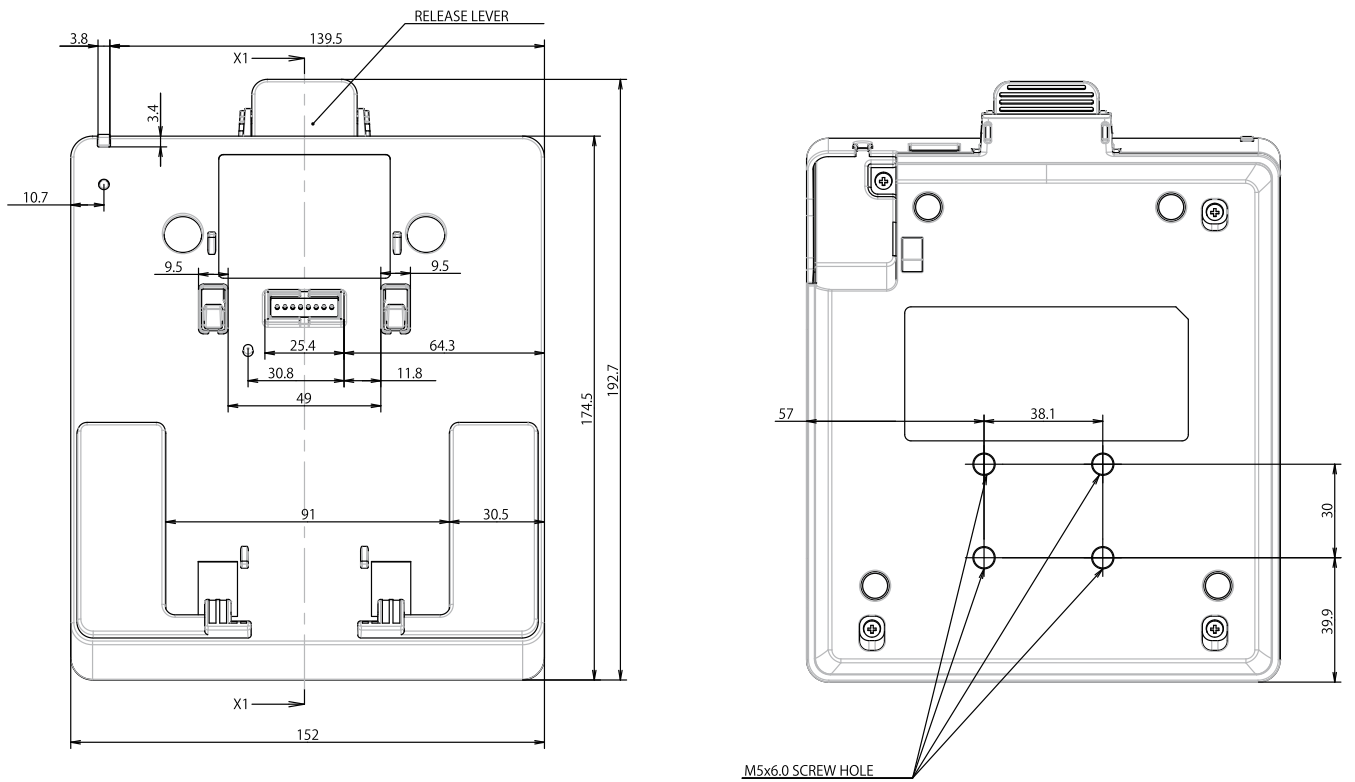

Side view

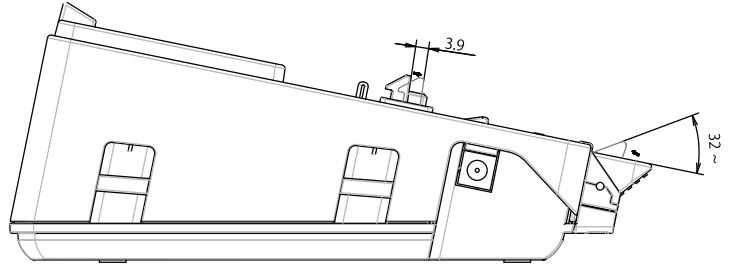
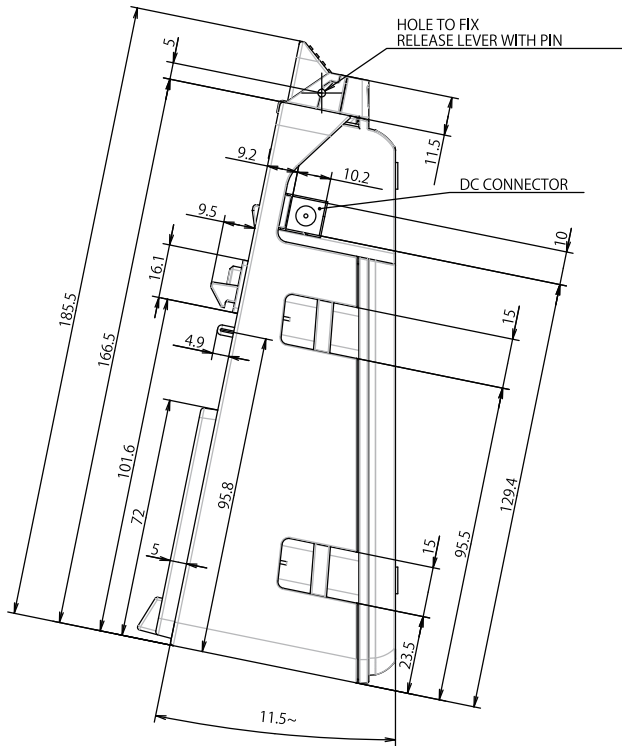

Cross section

X1-X1

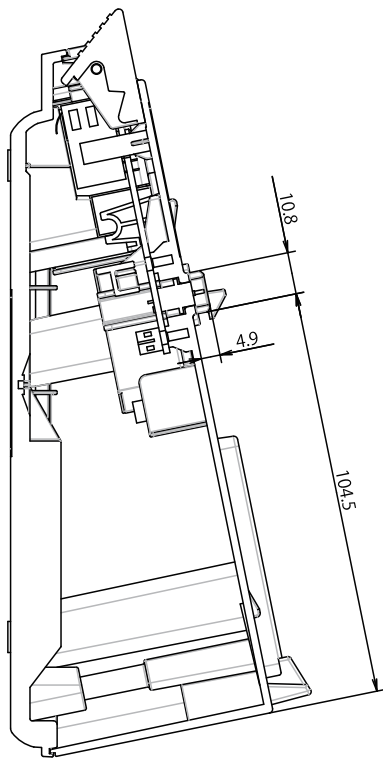

Back view

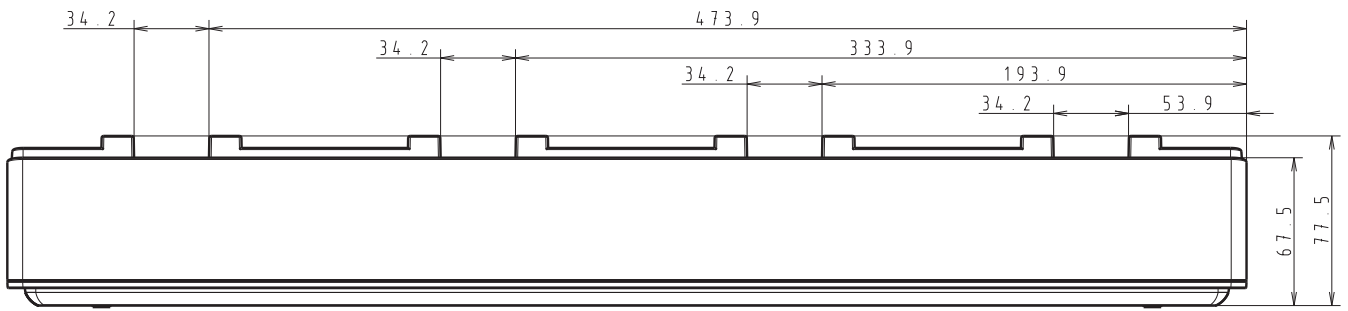

Side view

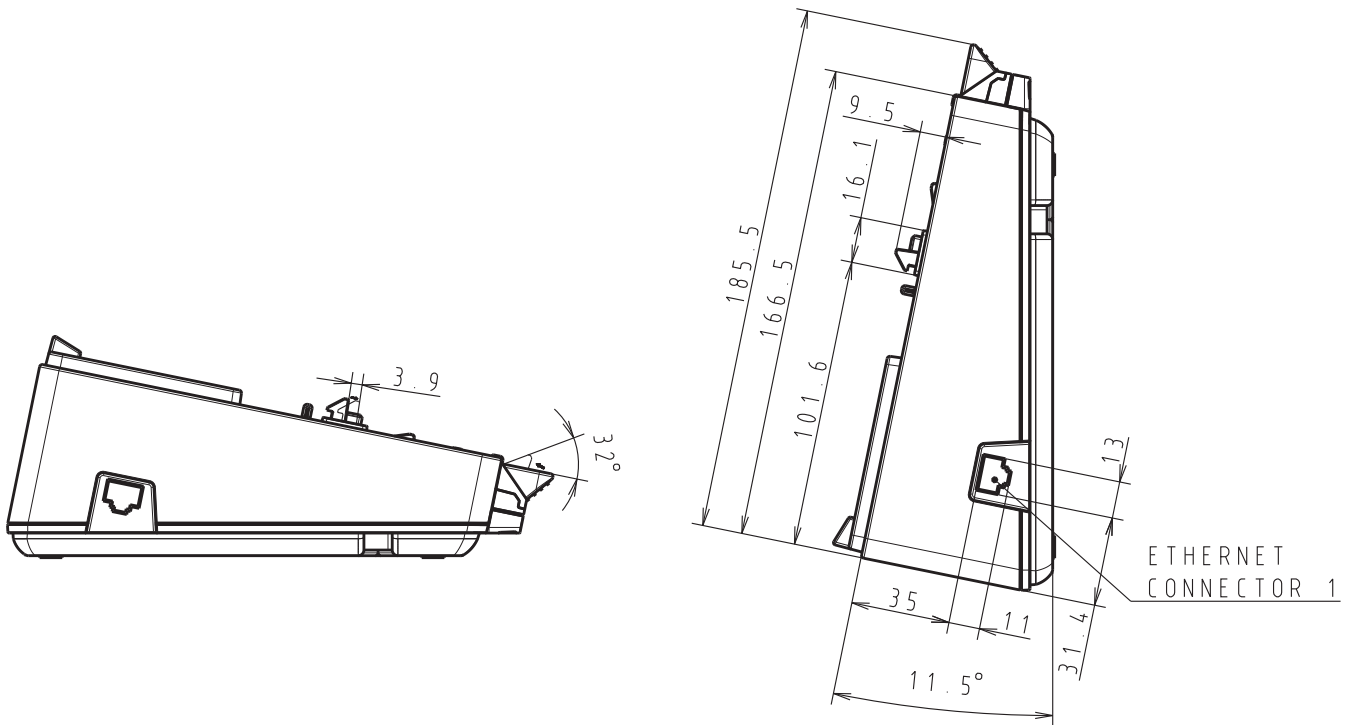

Cross section

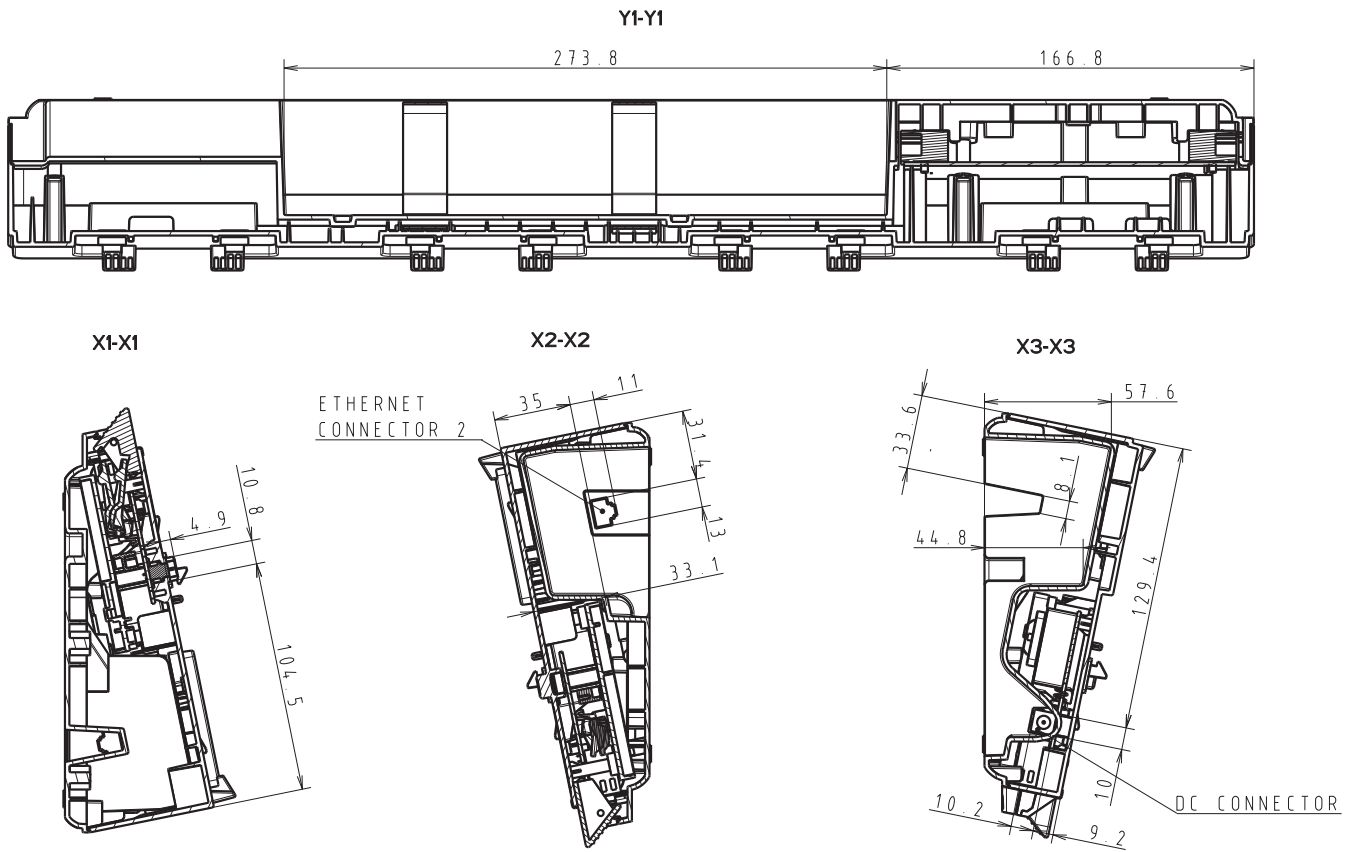

Related Information

- [Appendix](#)

Brother Help and Customer Support

IMPORTANT

For technical help, you must call the country where you bought the machine. Calls must be made **from within** that country.

>> [FAQs \(Frequently Asked Questions\)](#)

>> [For Customer Service](#)

>> [Ordering Accessories and Supplies](#)

FAQs (Frequently Asked Questions)

For more information on your Brother machine, visit the Brother support website at support.brother.com. For additional help and tips, go to your model's **FAQs & Troubleshooting** page; for the latest drivers and software, go to your model's **Downloads** page.

For Customer Service

In USA:

www.brother-usa.com/support (Self-Service/Email/Chat)

1-877-BROTHER (1-877-276-8437)

In Canada:

www.brother.ca/support

(Self-Service Videos, Email, Chat, Facebook and Twitter Help)

Service Center Locator (USA only)

For the location of a Brother authorized service center, call 1-877-BROTHER (1-877-276-8437) or visit www.brother-usa.com/support.

Service Center Locations (Canada only)

For the location of a Brother authorized service center, visit www.brother.ca/support.

Ordering Accessories and Supplies

For best quality results use only genuine Brother supplies, which are available at most Brother retailers. If you cannot find the supplies you need and have a Visa, MasterCard, Discover, American Express credit card, or PayPal account, you can order directly from Brother. Visit us online for a complete selection of the Brother accessories and supplies that are available for purchase.

NOTE

In Canada, only Visa and MasterCard are accepted.

In USA:

1-877-BROTHER (1-877-276-8437)

www.brother-usa.com/support

In Canada:

www.brother.ca



Related Information

- [Appendix](#)

Compatible Operating Systems

For the latest list of compatible software, visit support.brother.com.

Related Information

- [Appendix](#)
-

International ENERGY STAR® Qualification Statement (USA and Canada Only)

The purpose of the International ENERGY STAR® Program is to promote the development and popularization of energy-efficient office equipment.

As an ENERGY STAR® Partner, Brother Industries, Ltd. has determined that this product meets the ENERGY STAR® specifications for energy efficiency.



Related Information

- [Appendix](#)

brother



USA/CAN
Version A